

Advantages of Waterjet Technology: Versatility, Efficiency, and Productivity

Bruno Cicirello, Applications Engineer

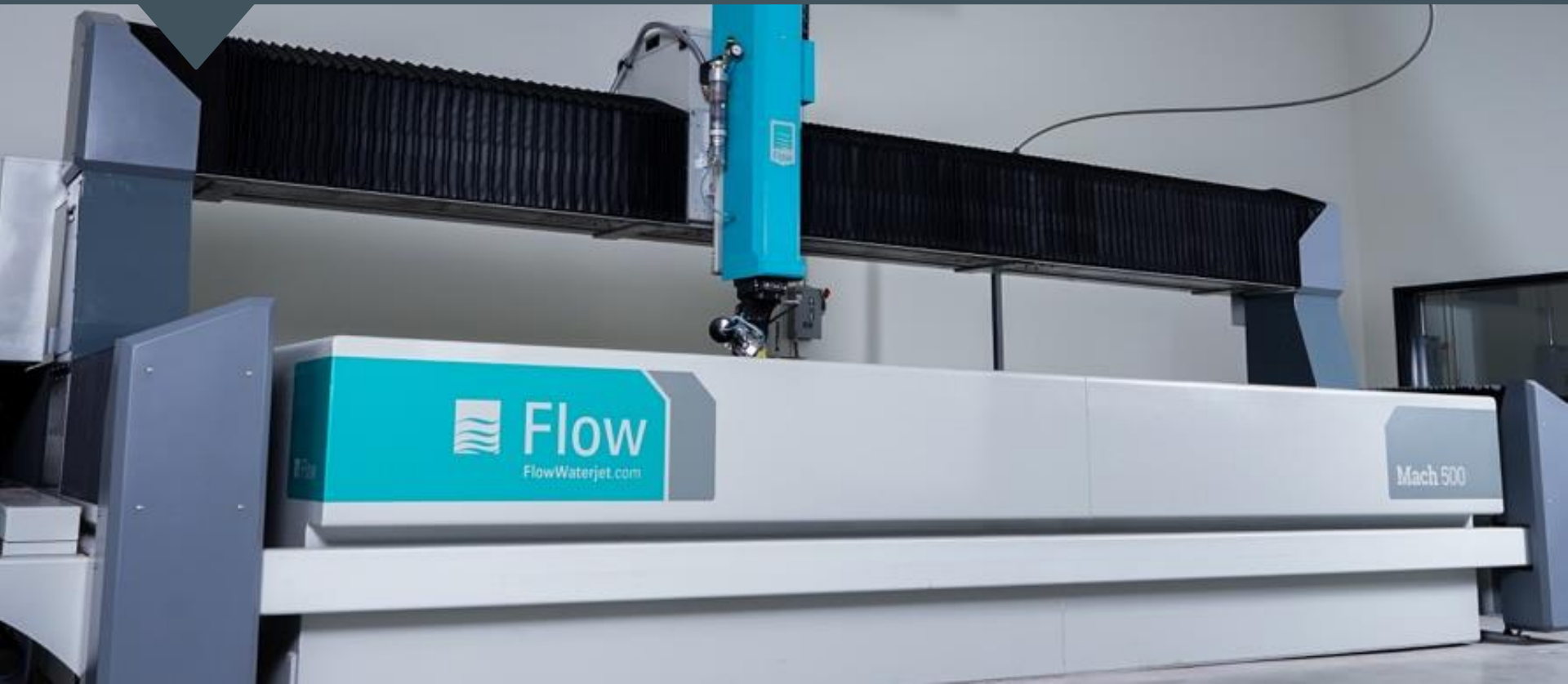



Recognized as one of the most versatile and fastest growing cutting processes used in manufacturing around the world, waterjet continues to augment and replace other cutting technologies.

How Waterjets Work

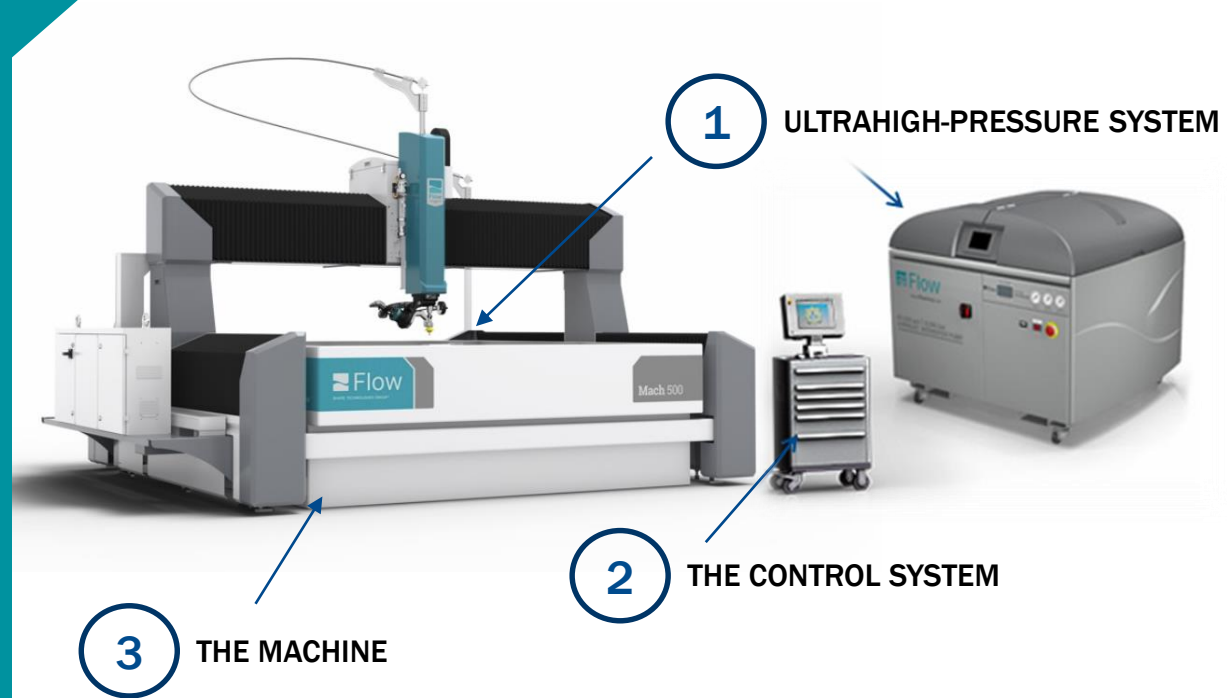

How Waterjets Work

Intensifier
Linear Pump

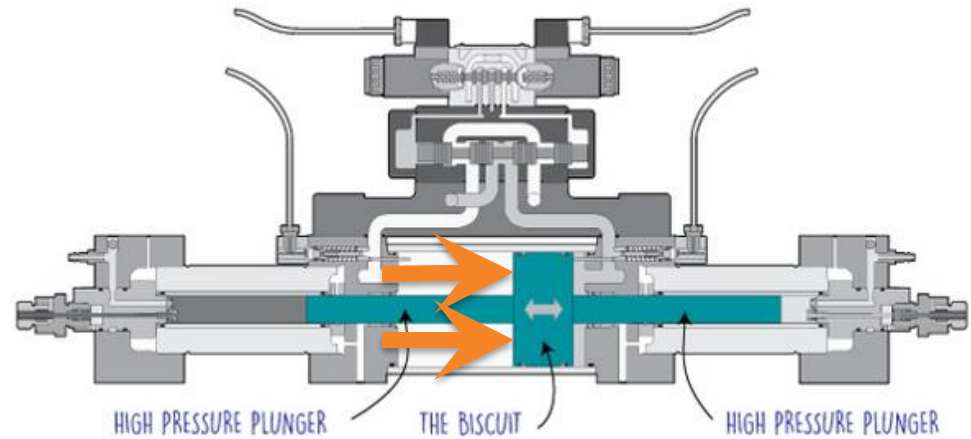

Direct Drive
Rotary Pump

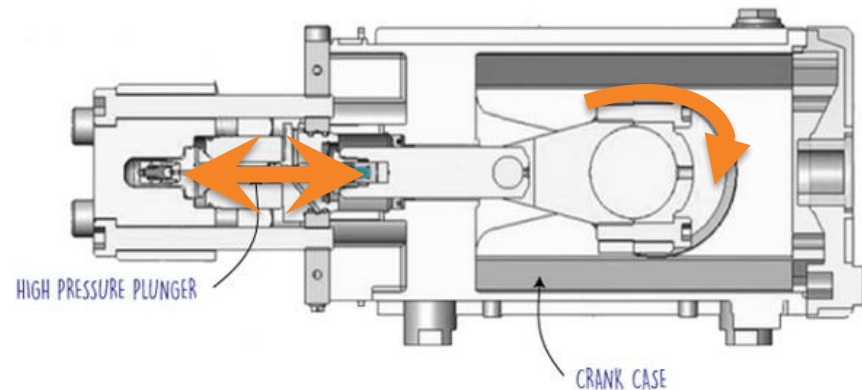

How Waterjets Work

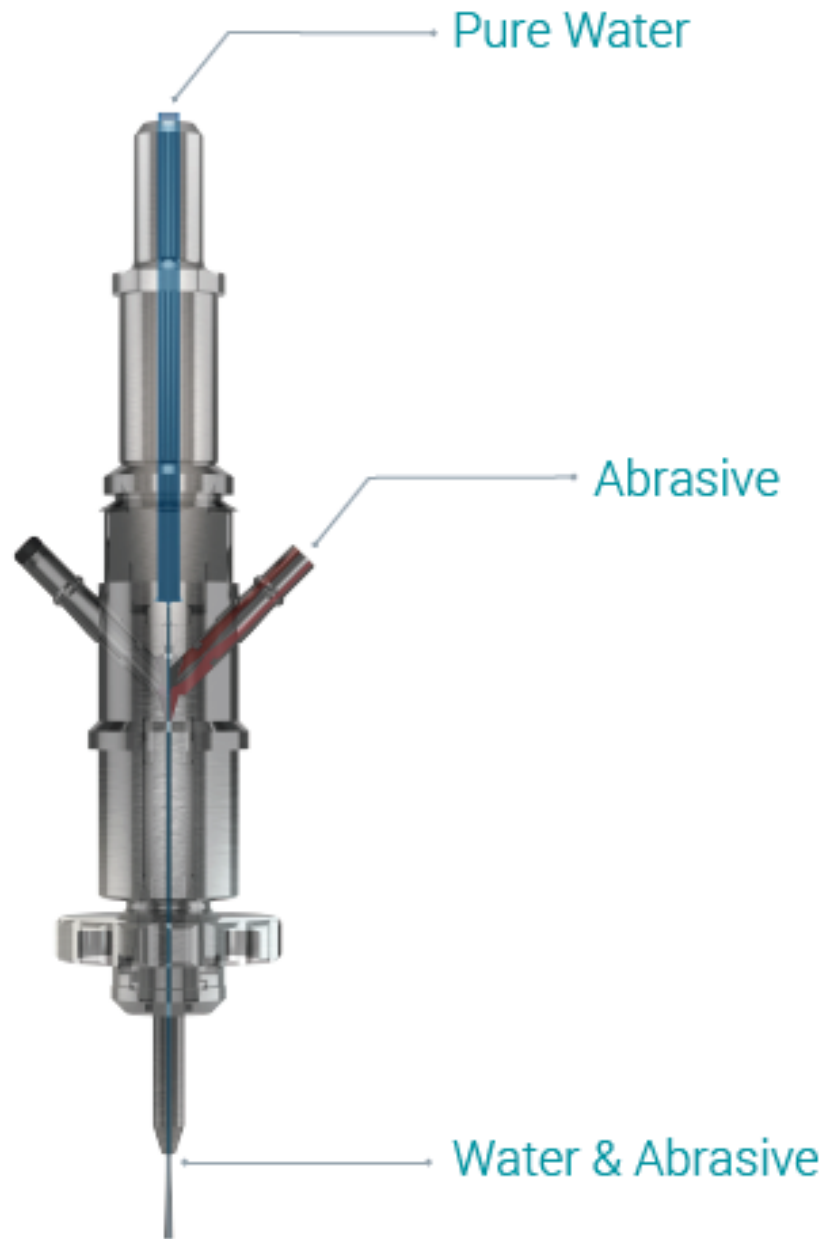

How Waterjets Work



Pure waterjet is:
~0.005" in diameter



Abrasive waterjet is:
~0.030" in diameter

Benefits Of Waterjet

The advantages of using a waterjet cutting system include:

Cold Cutting

The process generates little heat so materials are never altered.

Versatility

Waterjet does things no other technology can do from cutting whisper thin details in stone, glass and metals to cutting food products or thick titanium.

No Stress Added

Waterjet cutting doesn't induce warp on the target material.

Fast Turnaround

Waterjets typically vary only cut speed going from one material to the next, and cutting forces are very low resulting in very short part-to-part timeframe.

Environmentally Friendly

No noxious gases or liquids are used in waterjet cutting, and waterjets do not create hazardous materials or vapors.

Versatility is our biggest asset



Metals



Composites

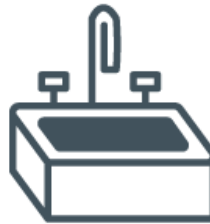

Stone & Tile



Foods



Glass



Paper Products



Stacked Materials

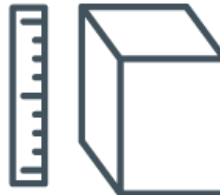

Thick Materials



Precision Cutting



Beveled Cutting

Waterjet is the ideal choice for any manufacturing organization looking to reduce costs & improve efficiency.

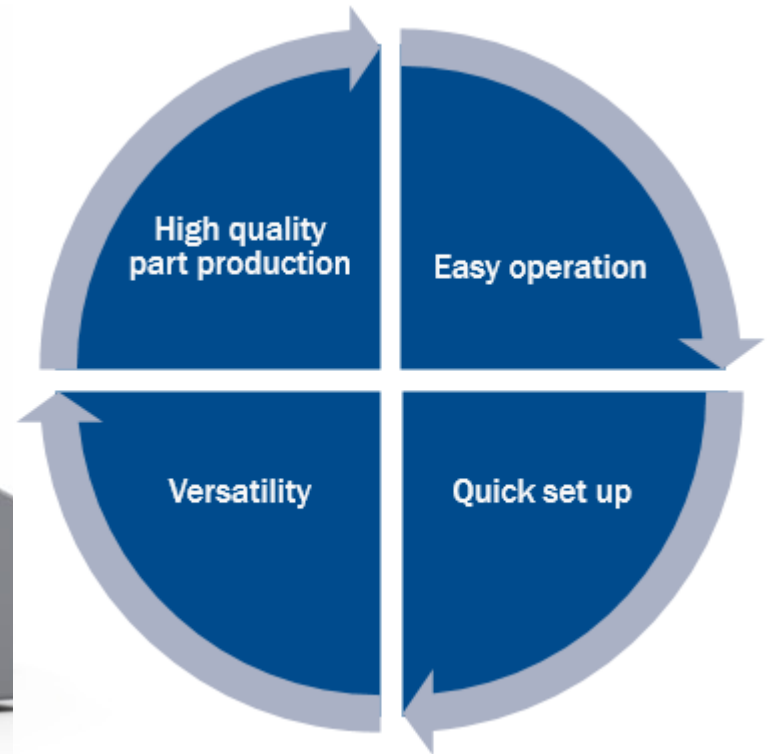
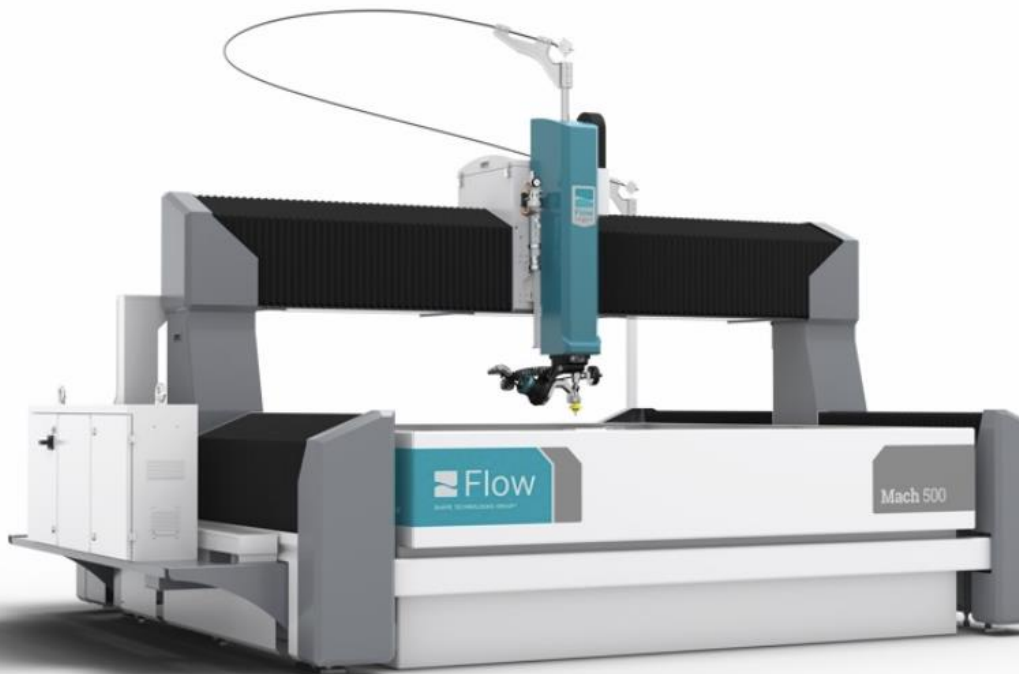

Waterjets are...



Highly Productive



Cost Effective



Revenue Generators



Environmentally
Friendly



Waterjets Are Highly Productive

Efficiency improvements through pressure

The pump is the heart of the waterjet system, continuously delivering pressurized water to the cutting head.



Rotary Direct Drive Pump
Rated up to 60,000 psi [4,150 bar]



Linear Intensifier Pump
Rated up to 94,000 psi [6,500 bar]

Efficiency improvements through pressure

As pressure increases, the stream diameter shrinks, the stream velocity increases, and less abrasive is used.

90K
PSI

JET VELOCITY 2,550 mph

.030
Jet Width

60K
PSI

JET VELOCITY 2,040 mph

.045
Jet Width

40K
PSI

JET VELOCITY 1,665 mph

.060
Jet Width

Fast turnaround



quote



program

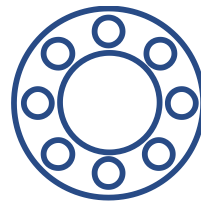

cut

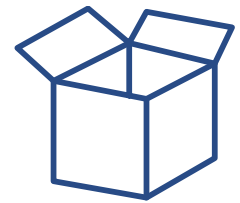

ship

Fast turnaround



quote



program

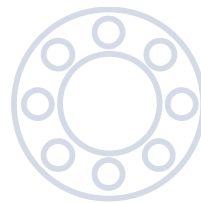

cut

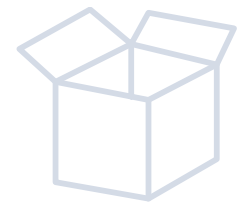

ship

Easy Quoting

Program your part and FlowMaster[®] delivers the machine operating cost and the cycle time to produce it.

Fast turnaround



Fast Programming

- Import or draw your part in any software
- Auto path your part
- Lead in/lead outs are added
- Machine cuts the inside holes first then outside perimeter

Fast turnaround

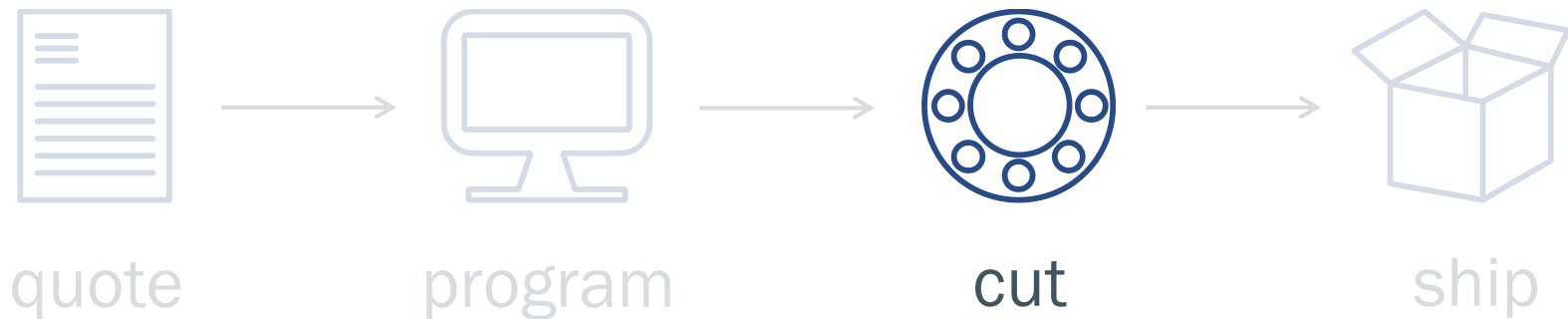

Efficient Cutting

- Enter material, thickness and desired quality
- Erichsen Models, the jet slows down on corners and speeds up on straights
- Use 100 different quality settings to produce the shortest cycle time for the quality you need
- Cut your part right the first time

Complements existing technology

A close-up photograph of a waterjet cutting process. A metal nozzle is positioned vertically, cutting through a dark material. A bright blue hose is connected to the side of the nozzle. A dense spray of bright orange sparks is being ejected from the cutting point, creating a large, fan-shaped plume of light. The background is dark and out of focus.

Most fabricators find that waterjet complements other technology investments thus improving overall shop efficiency.

Complements existing technology

A close-up photograph of a waterjet cutting process. A dark, cylindrical nozzle is positioned on the right, emitting a fine, white spray of water and abrasive particles onto a dark, textured metal surface. The background is a bright, saturated blue. The text "WATERJET MAKES THE BEST EDGE." is overlaid in white, bold, sans-serif font across the center of the image.

WATERJET MAKES THE BEST EDGE.

No edge damage: completely free of heat damage and stress.

Satin smooth: 80 to 125 Ra surface finish on all abrasive waterjet cut surfaces. Smoother on pure waterjet cuts

No secondary operations: parts usually used as is, except for tapping, bending, etc.

Precision to take on different types of work

Waterjet systems can be configured with different levels of precision capability.



Conventional Waterjet

+/- 0.005 to 0.015"
(+/- 0.13 to 0.4mm)



Dynamic Waterjet®

+/- 0.001 to 0.003"
(+/- 0.03 to 0.08mm)



Dynamic XD®

Same accuracy as Dynamic Waterjet, except provides bevel & 3D cutting



Waterjets Are Cost Effective

Reduce capital cost

| Machine Type | Typical purchase price |
|--------------|------------------------|
| EDM | \$125k |
| Plasma | \$140k |
| Waterjet | \$160k → |
| Fiber Laser | \$250k |
| CO2 Laser | \$500k |



Reduce material waste and secondary operations

Improving material utilization adds cash directly to the bottom line.



Can You Stack Material?



Stacking with waterjet can increase your product and profits.

- When cutting thin sheet metal, layers are stacked to a thickness of 0.6 inch
- With Dynamic Waterjet® the top part and bottom part hold the same tolerance

Preventative Maintenance

Break Fix, No More

Maintenance time, operating cost, and uptime can be optimized with a waterjet system.

If you have a service contract with an OEM partner like Flow, then the basic maintenance of the high-pressure system are all taken care of by highly skilled local service engineers.





Revenue Generators

Real World Examples

Howe & Howe Technology



Unique, exotic personal & military vehicles in small and medium batches

Needed more material versatility
Fast art to part, especially for complex parts
Ideal for creative projects

Plasma required grinding off heated edge
Tolerances were not tight enough
Left taper on the parts (upside down V)

Central Cal Metals Metalworking



Traditional fab shop with sheet metal processing equipment and many lasers.

Thicker cutting

Highly reflective materials: Aluminum, Copper, Brass

EMS Fabrication Shop

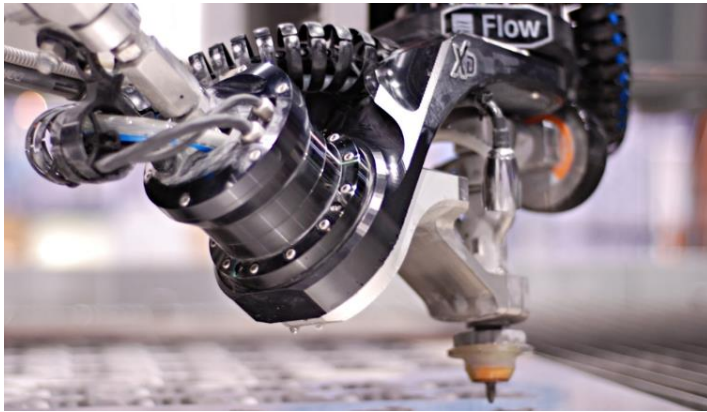

Plasma

Waterjet

EMS

Traditional fab and machine shop,
used plasma

Why Waterjets?

- No heat affected material
- Very tight tolerances

“The tolerances are so tight, parts fit together like a puzzle... it used to take two guys nearly two weeks to complete the job (when using parts from plasma cutting). Now, one guy can get the job done in just two days.”



Environmentally Friendly

No hazardous waste

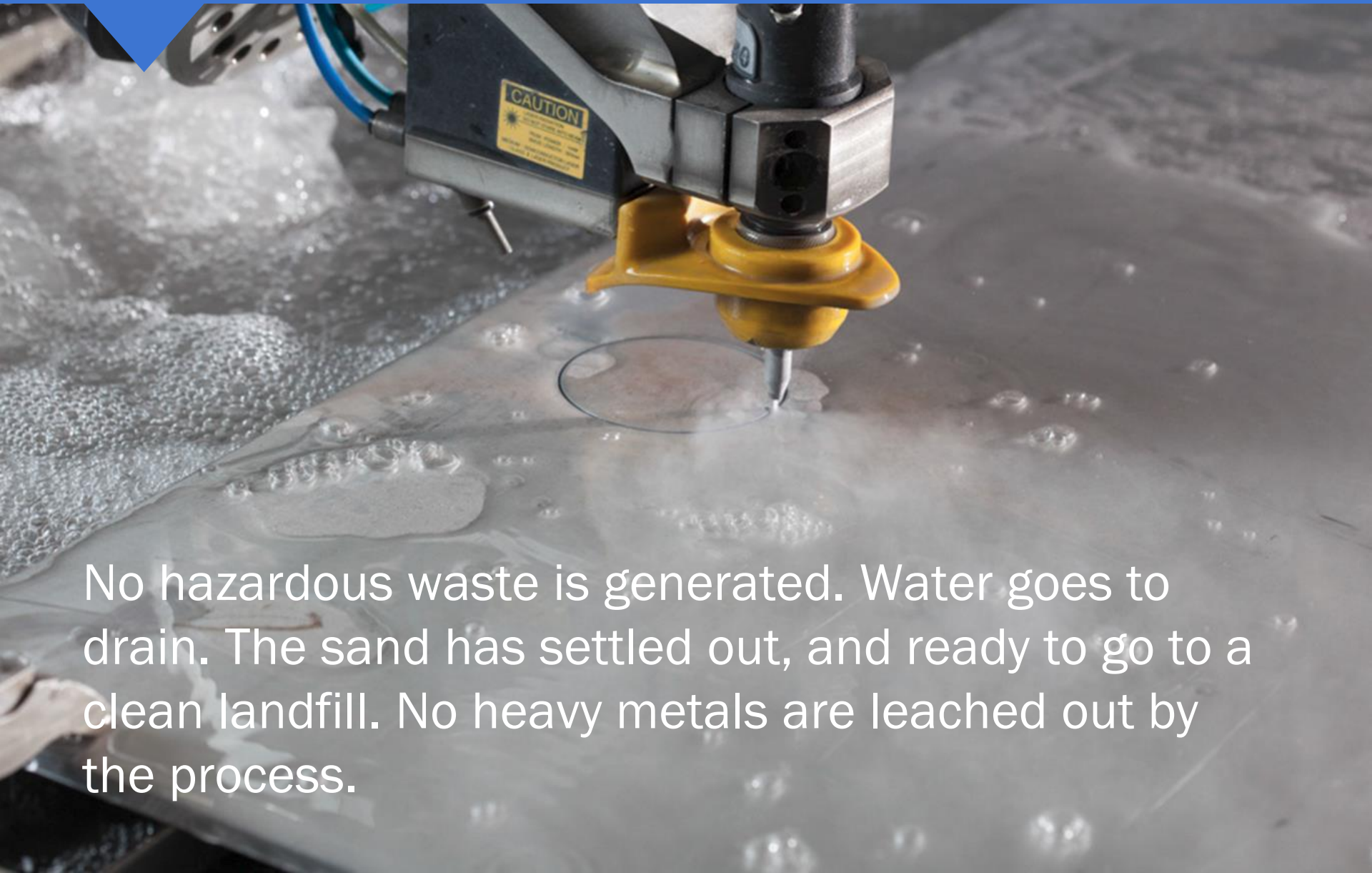

No hazardous waste is generated. Water goes to drain. The sand has settled out, and ready to go to a clean landfill. No heavy metals are leached out by the process.

Quieter and Cleaner

Advanced systems provide water level control.

When cutting under water, the process is much quieter than many other cutting methods, emitting only a murmur down inside the catcher tank.

Waterjets are...



Highly Productive



Cost Effective



Revenue Generators



Environmentally
Friendly

Questions?

For additional questions or a free test cut
visit us at booth #2019 or our website at
www.FlowWaterjet.com