

southtec[®]

ARTIFICIAL INTELLIGENCE FOR MACHINING

TONY SCHMITZ

PROFESSOR, UNIVERSITY OF TENNESSEE, KNOXVILLE
JOINT FACULTY, OAK RIDGE NATIONAL LABORATORY



Outline

- Self-aware manufacturing
- Physics-guided machine learning
- Machining background
- Stability modeling
 - ANN
- Expanded stability modeling
- Summary

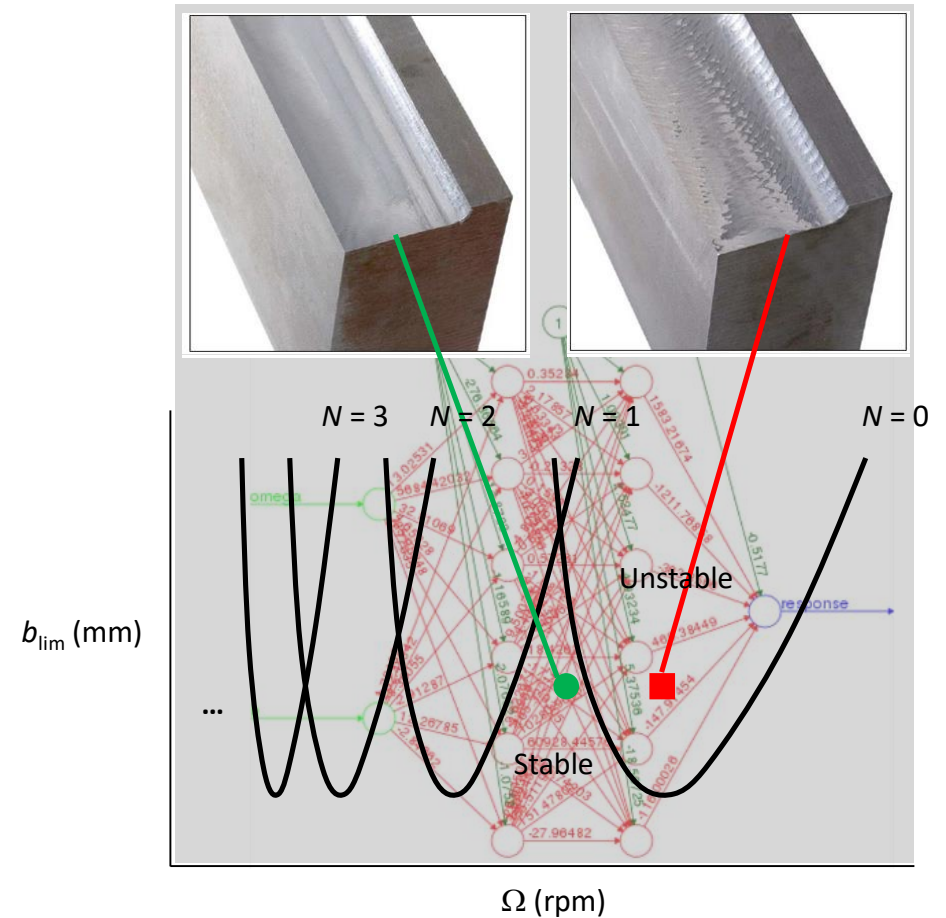

Outline

- **Self-aware manufacturing**
- Physics-guided machine learning
- Machining background
- Stability modeling
 - ANN
- Expanded stability modeling
- Summary

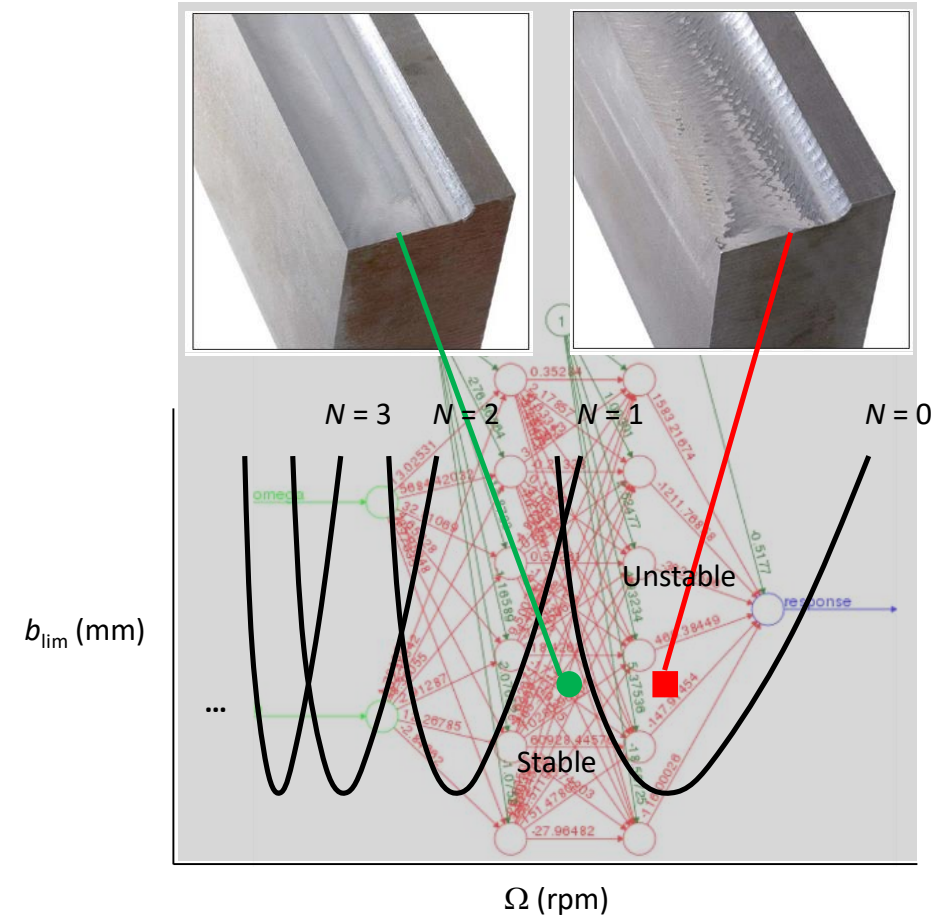

Self-aware operation

- ability of a production or measuring machine to understand its current state and surroundings and respond

Approach

- combine physics-based and machine learning models to provide hybrid physics-guided machine learning approaches

Goal

- improve the accuracy, physical consistency, traceability, and generalizability of model predictions to improve manufacturing productivity

Project domain

- artificial intelligence
- machining process modeling
- stability, tool wear, part accuracy, surface finish, machine limitations...

Why now?

- new computing technologies and data are transforming manufacturing from empiricism to science, analog to digital
- global competitors (e.g., Germany's Industry 4.0 and China's Made in China 2025)
- US industry, especially SMEs, are looking to adopt new technology (artificial intelligence, smart manufacturing, Industry 4.0, Industrial Internet of Things, cloud computing, digital thread, digital twin, ...)

Digital thread

- communication framework that enables seamless data flow and an integrated view of manufacturing processes
- links every phase of life cycle from design, production, and testing through end use
 - digital solid model produced using CAD software
 - CNC machining instructions produced using CAM software
 - measurements performed to ensure conformance to design specifications
 - all data partnered with physical part as digital twin

Challenges

- human intervention is still required at nearly all stages
 - high volumes of data must be manually interpreted and implemented
 - CAM part program is manually produced for every part by programmer

Outline

- Self-aware manufacturing
- **Physics-guided machine learning**
- Machining background
- Stability modeling
 - ANN
- Expanded stability modeling
- Summary

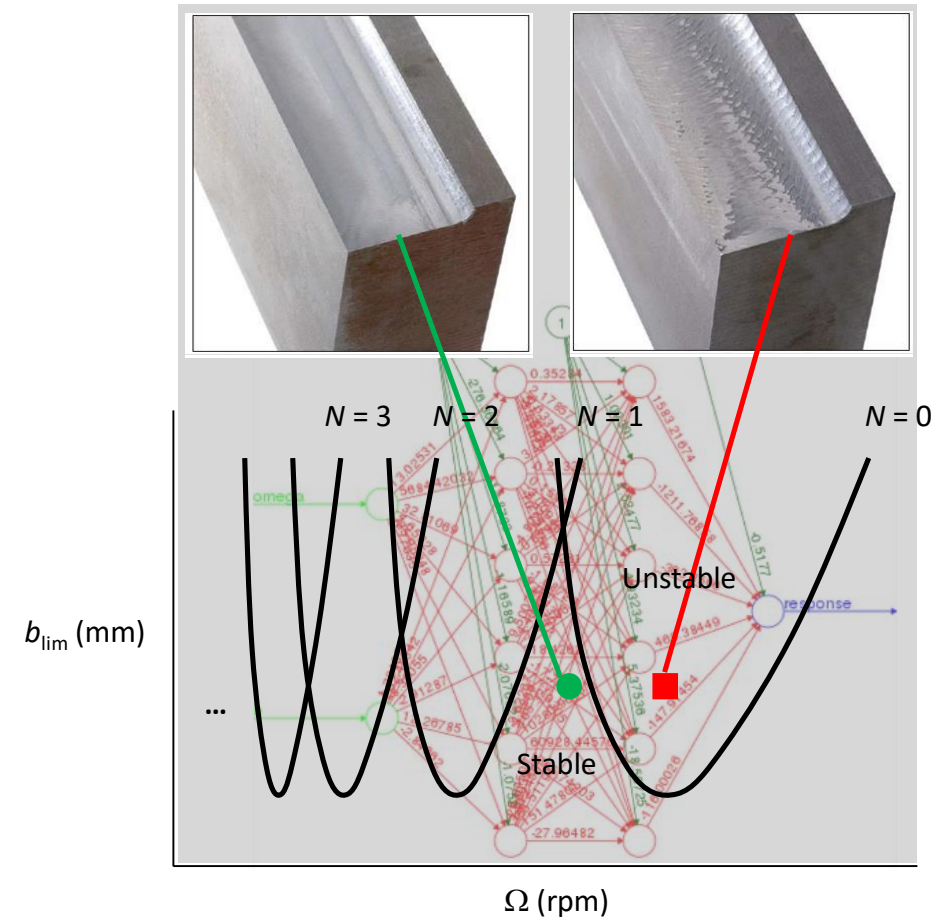

Physics-guided machine learning

Modeling complex industrial processes

- data-driven
- physics-based

Data-driven approaches

- machine learning and statistical techniques
- learn directly from sensor data and measurement results
- advantage when relationships between the input and output variables are difficult to describe using physics
- challenge is that they are agnostic to physical laws
 - dependent on data quality
 - may not generalize beyond the training data set

Physics-based models

- preferred for scientific discovery
- challenges include
 - every model is an approximation of reality
 - model input parameters require identification, estimation, and calibration
 - input uncertainty is propagated to output uncertainty

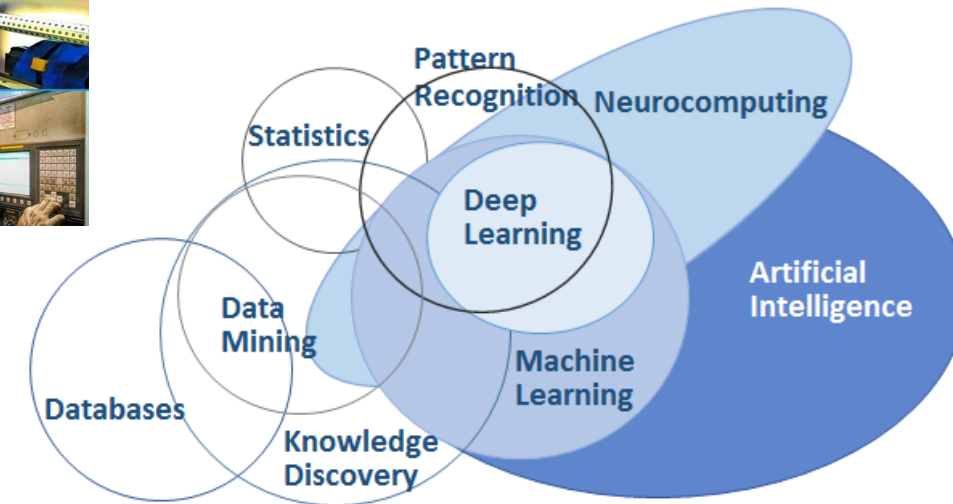
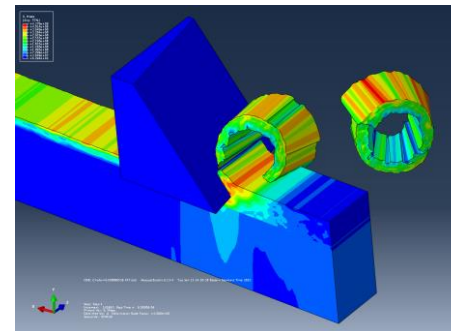

Hybrid physics-guided machine learning

- combine data-driven and physics-based models with process measurements
- penalize results that are inconsistent with physical knowledge
 - assure physical consistency of model predictions
 - improve capability to generalize to other situations
 - enable model output to be incorporated in new scientific discovery efforts

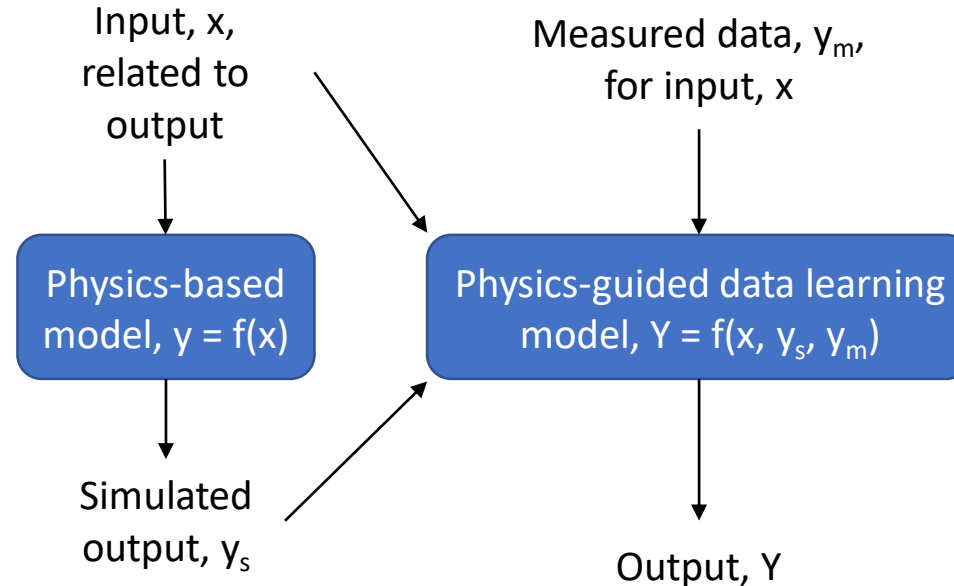

Outline

- Self-aware manufacturing
- Physics-guided machine learning
- **Machining background**
- Stability modeling
 - ANN
- Expanded stability modeling
- Summary

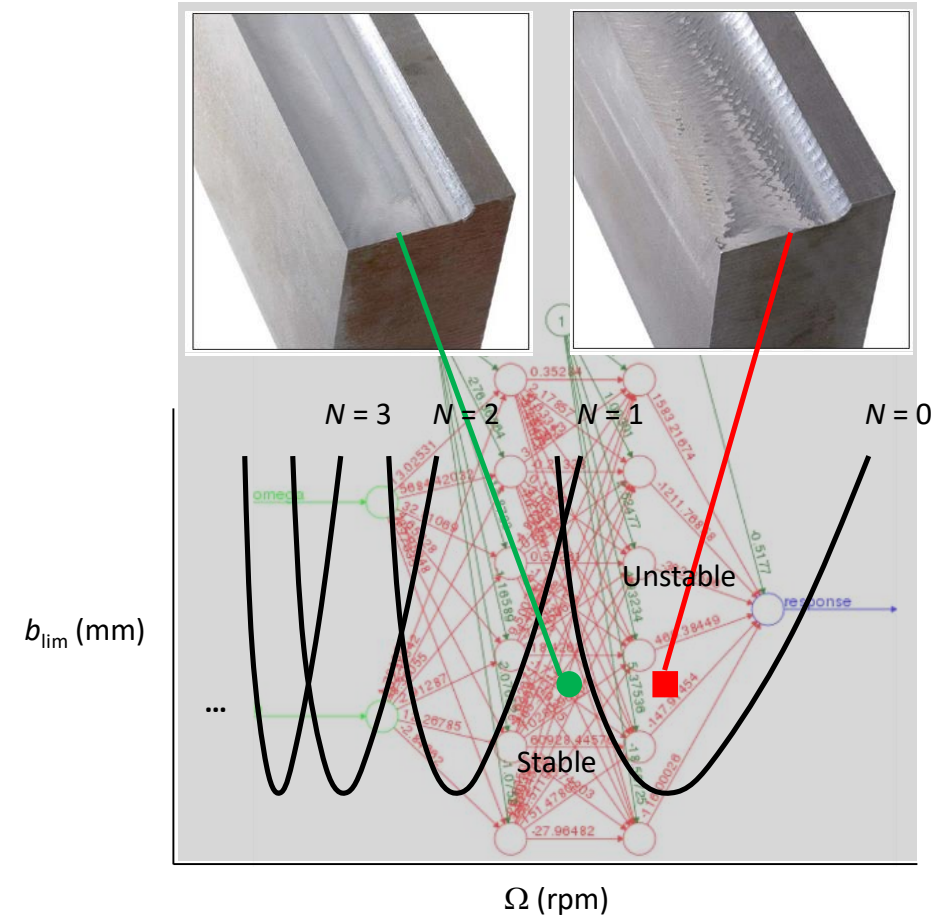

Machining

- use defined cutting edge to shear away material (chips) and leave desired geometry

Considerations

- path planning
- fixturing
- tooling (selection, balancing, holder type)
- coolant management
- machine accuracy
 - quasi-static positioning
 - dynamic positioning
 - thermal errors
- tool/workpiece vibrations
- chatter

Machining background

Chatter

- self-excited vibration
- large forces
- large displacements
- poor surface
- tool/workpiece damage



Machining background

Tool flexibility

- cutting tools are designed to be stiff
- the materials are selected to be hard and resist deformation.
- when the cutting force is applied to the tool it still deflects
- can think of a tool as a stiff spring

Workpiece flexibility

- sometimes the workpiece is also flexible
- workpiece can deflect as much or more than the tool when the cutting force is applied
- can also be thought of as a spring

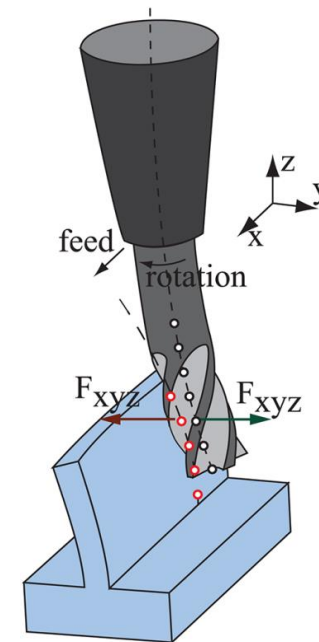
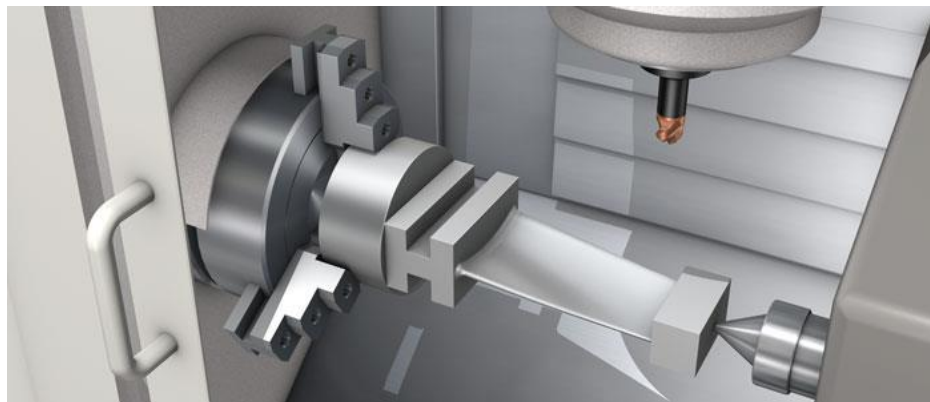
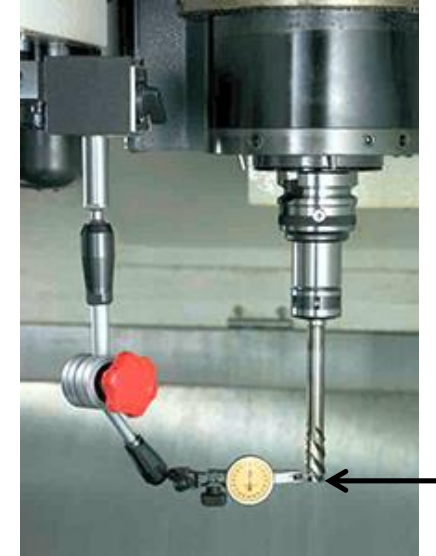

Machining background

Cutting force

- generated as the tool shears away material in the form of a chip

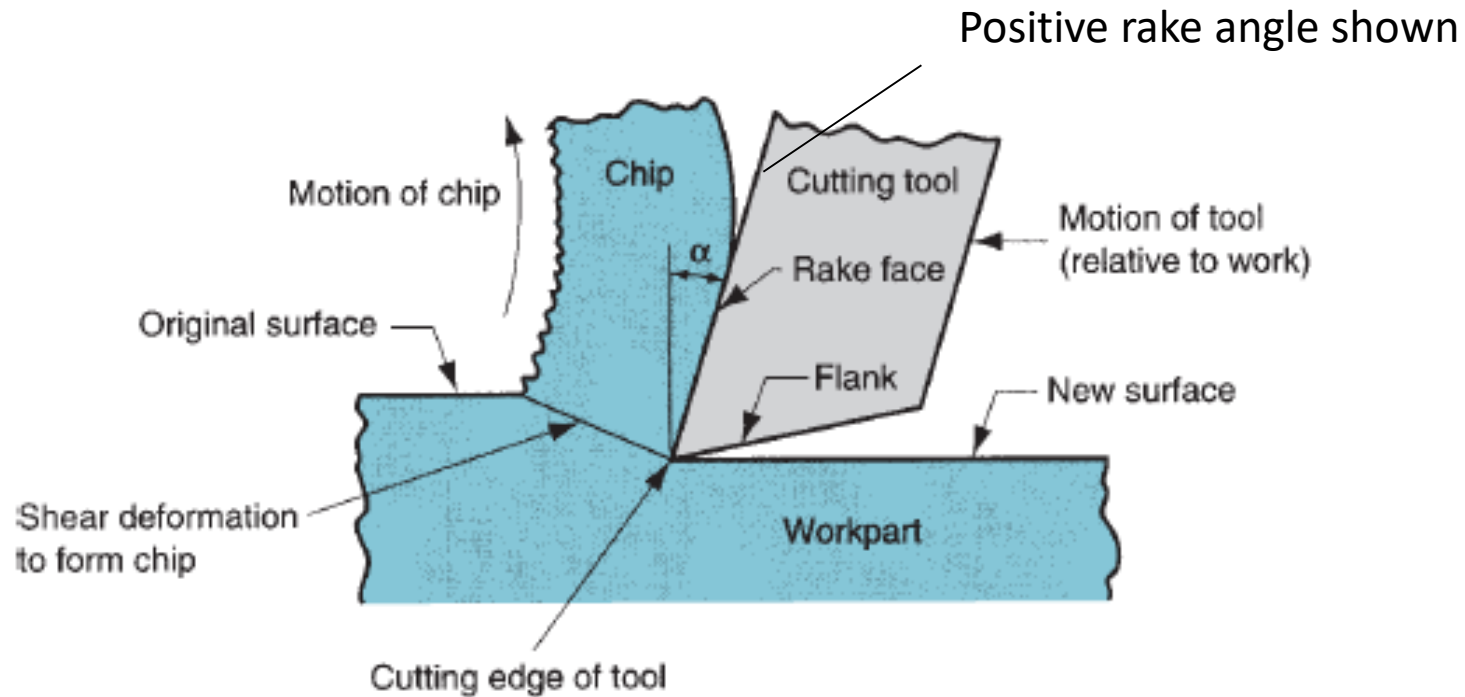

- cutting force depends on the chip thickness, chip width (into screen), material properties, and tool geometry
- larger chip width/thickness and negative rake angle gives higher force

Why does vibration occur in milling?

- teeth constantly enter and exit the cut
- the cutting force varies with these entries and exits
- the variable cutting force acts on the flexible tool and/or workpiece and causes displacement
- this variable displacement is vibration
- the amplitude of vibration depends on the tool/workpiece stiffness and spindle rotating frequency

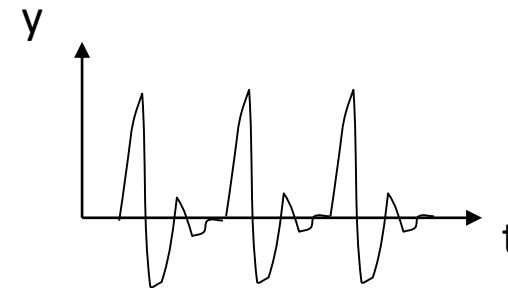
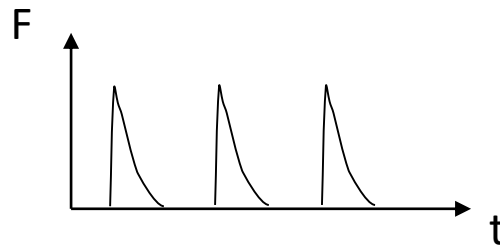
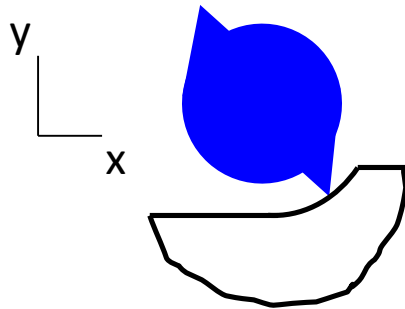

There are two main types of vibration in milling.

1) Forced vibration

The variable force causes the tool or workpiece to vibrate at the same frequency. For a spindle speed of 12000 rpm and a cutter with two teeth, the tooth passing frequency is $12000/60 \times 2 = 400$ Hz.

- vibration magnitude depends on the relationship between the tooth passing frequency and the tool/workpiece dynamics
- describe the dynamics using the frequency response function, or FRF

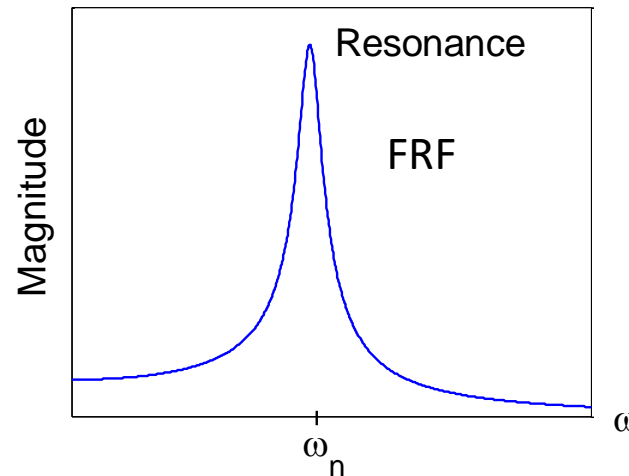
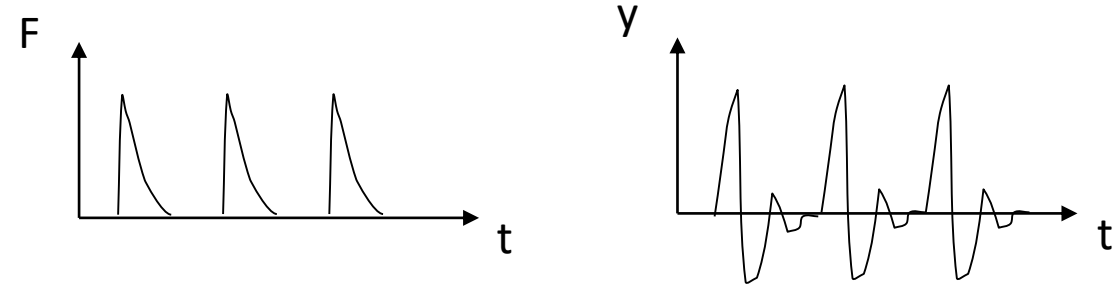

Machining background

2) Self-excited vibration

- Steady input force is modulated into vibration near the system natural frequency

Examples include:

- whistle - steady air flow produces acoustic vibration
- violin - bow across string produces vibration at frequency that depends on the string length
- airplane wing flutter
- chatter in machining - steady excitation of teeth impacting work leads to large tool vibrations near system natural frequency

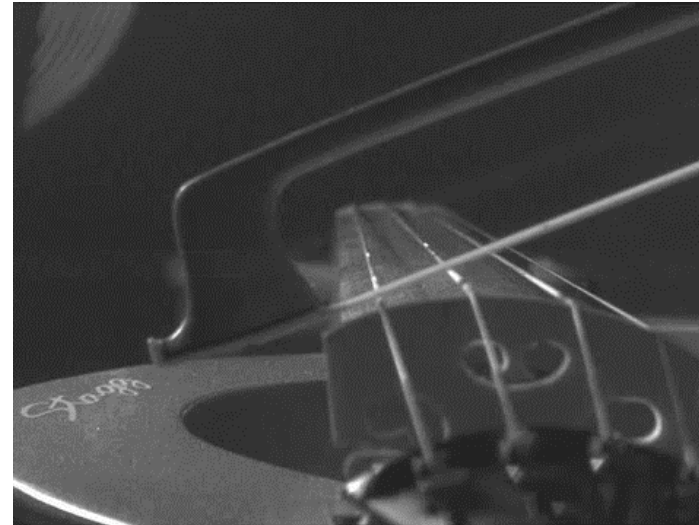
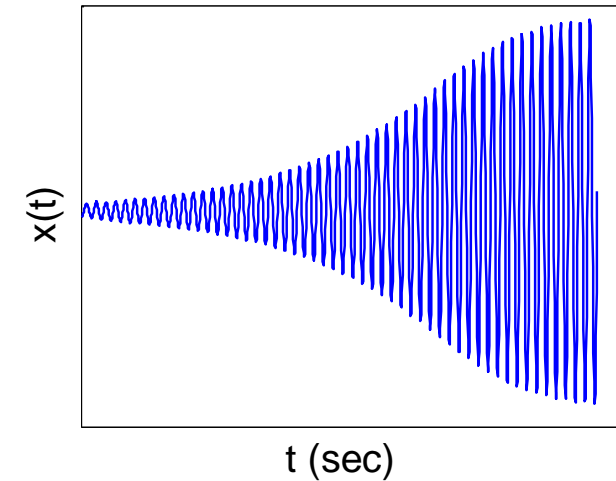

Tacoma Narrows Bridge (Galloping Gertie) opened in July 1940, but collapsed due to aero-elastic flutter four months later.

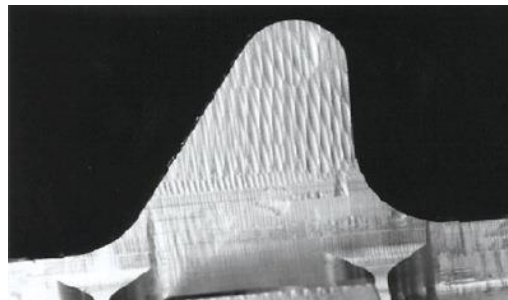
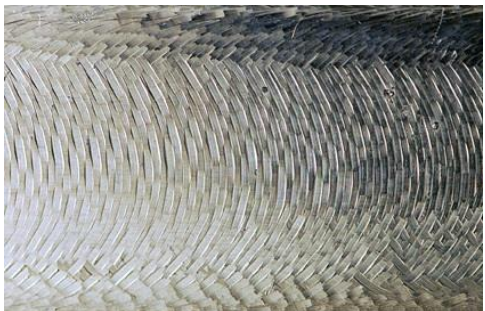

Why does chatter (self-excited vibration) occur in machining?

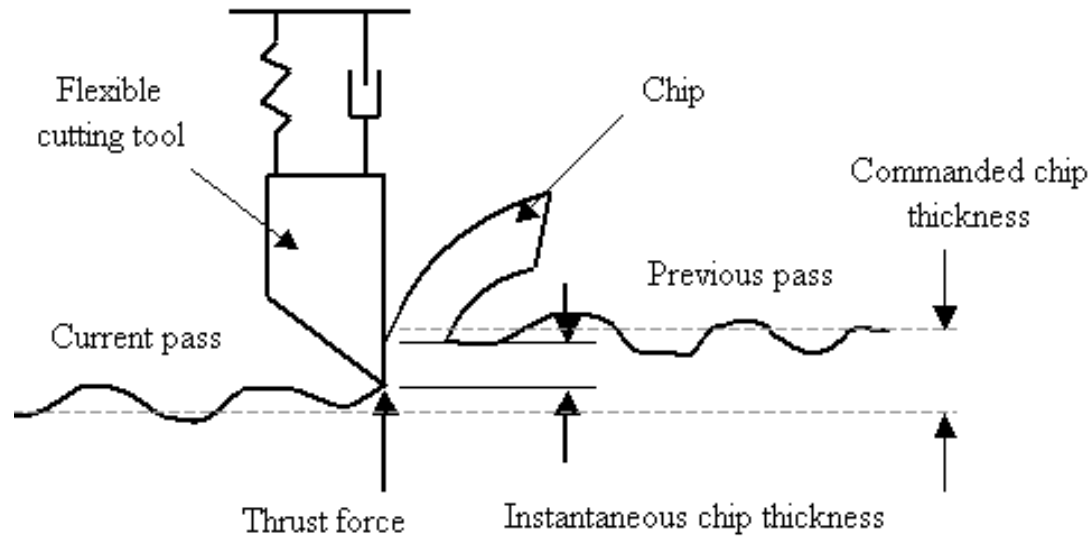

Regeneration is a primary mechanism for chatter

- force depends on chip thickness
- chip thickness depends on current vibration and previous pass
- current vibration depends on force

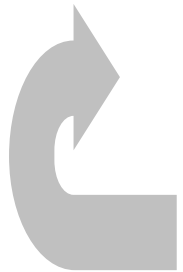

feedback

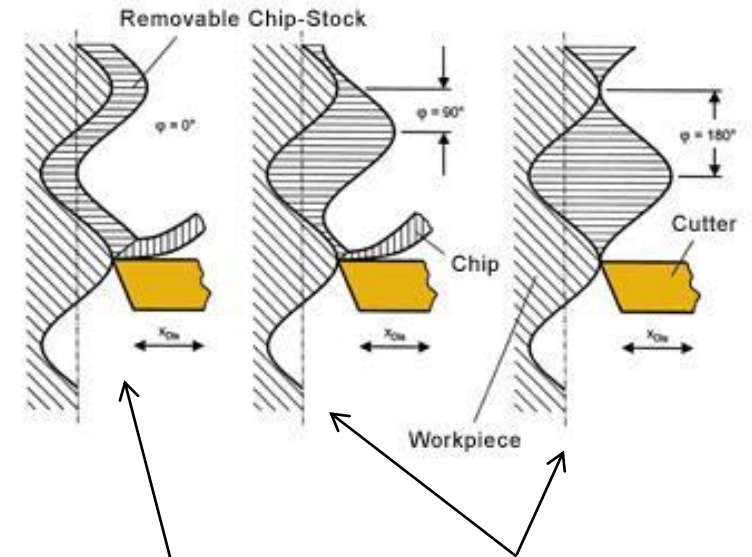

Chip thickness varies so force varies \rightarrow unstable

Chip thickness is nearly constant – small force variation \rightarrow stable

Machining background

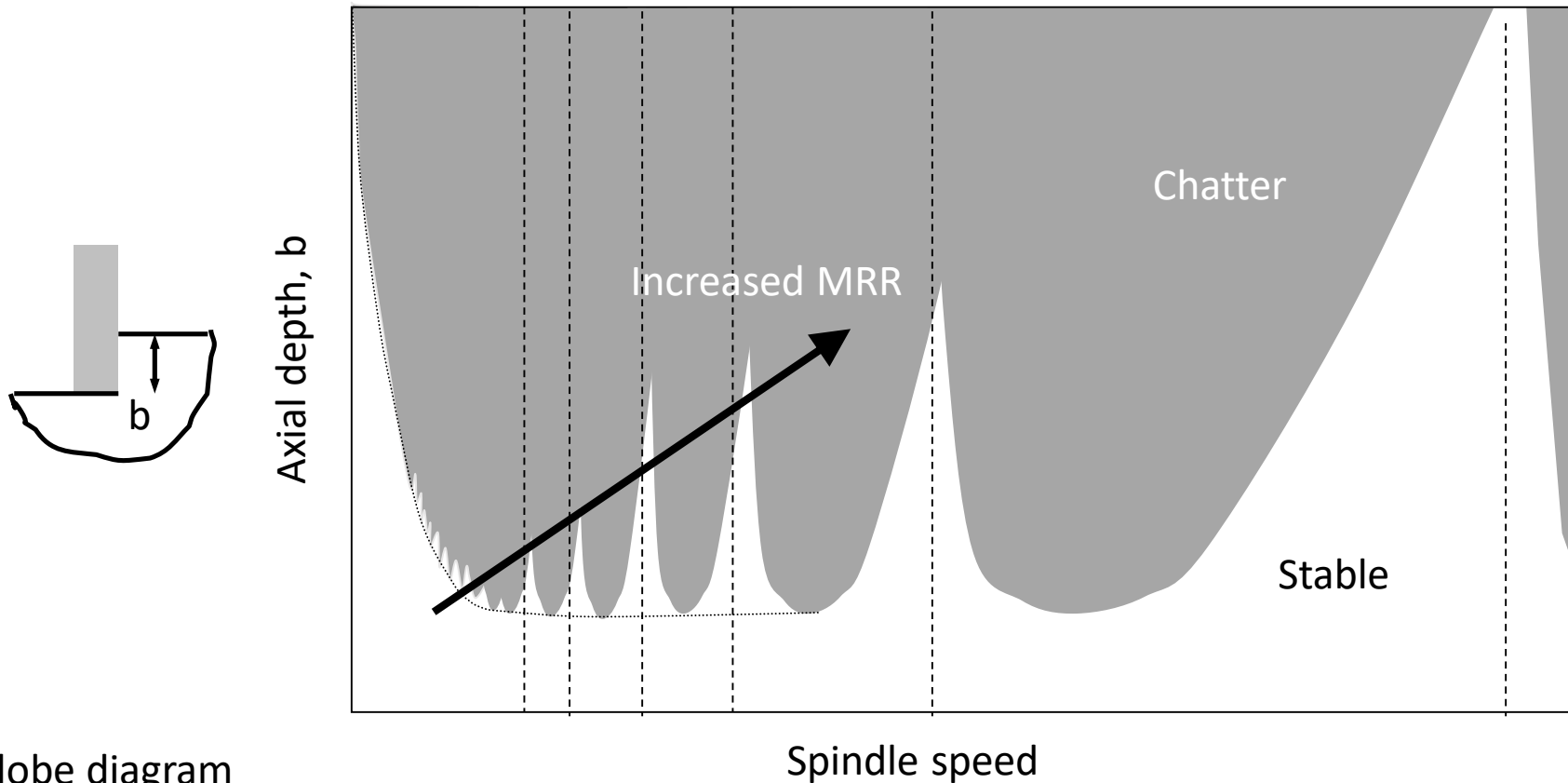

Stability lobe diagram

- separates unstable (chatter) from stable (forced vibration) zones
- select spindle speed and axial depth combination to obtain stable cutting conditions without trial cuts
- best spindle speeds depend on dynamics and probably do not correspond to handbook values



How do the two vibration types relate to the stability lobe diagram?

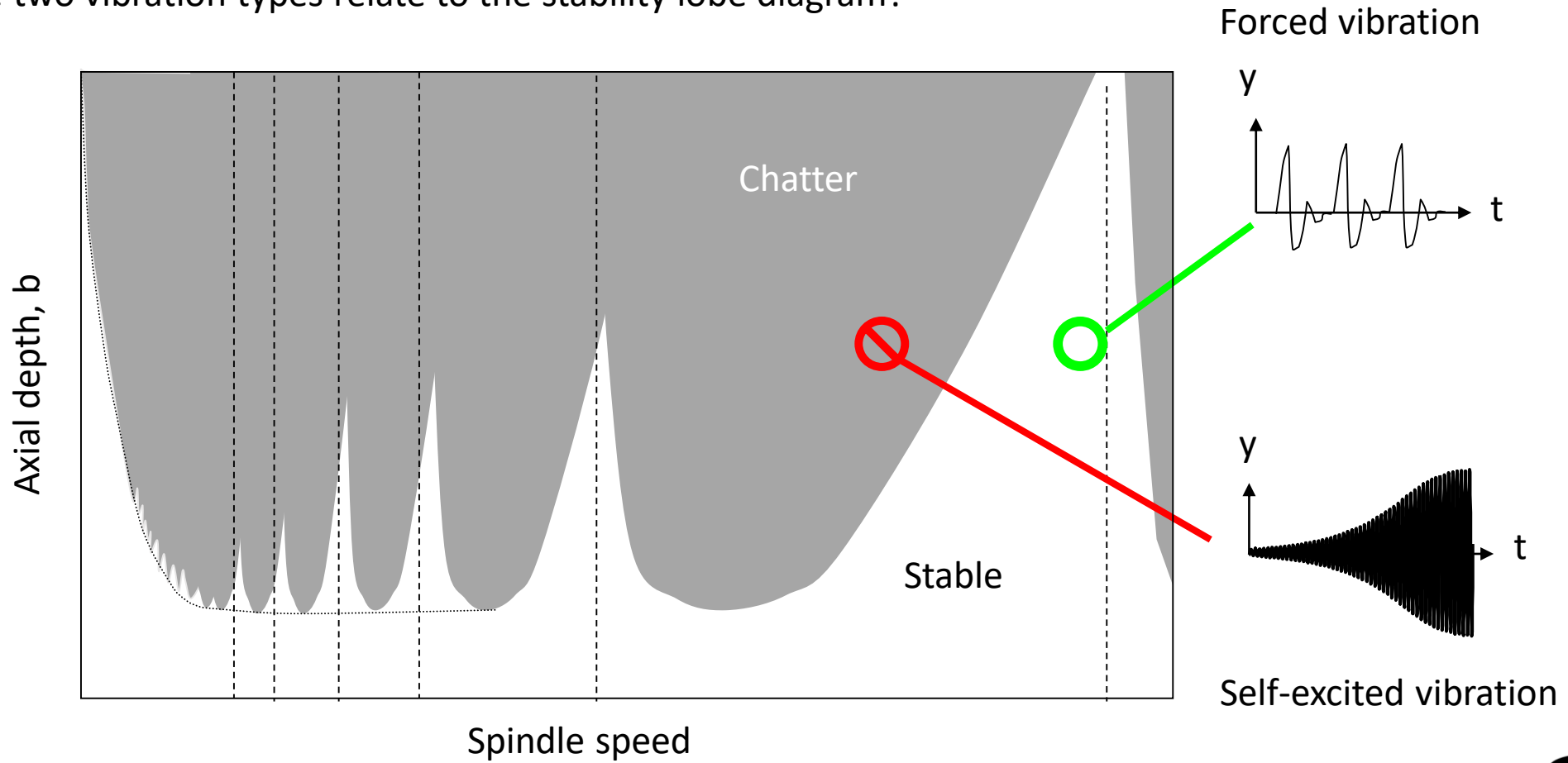

What about the chip thickness variation?

Machining background

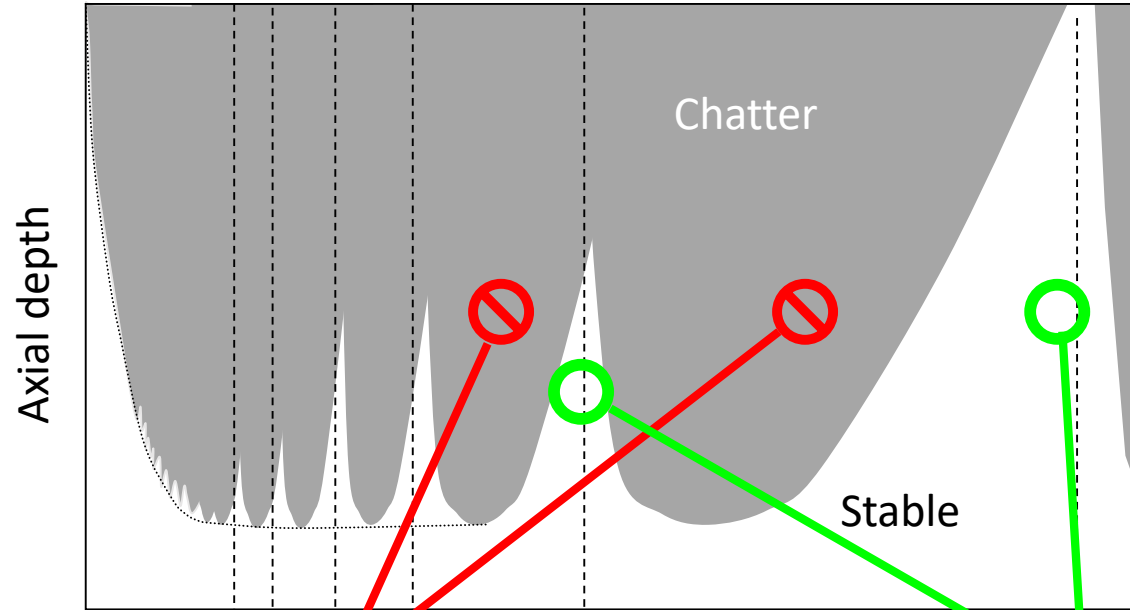

Milling: tooth to tooth

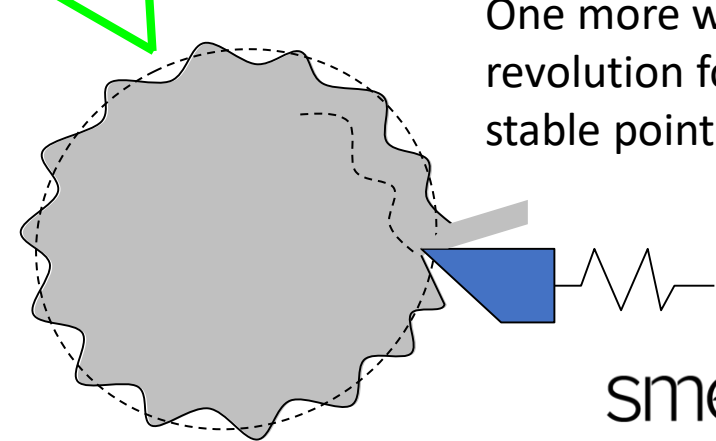
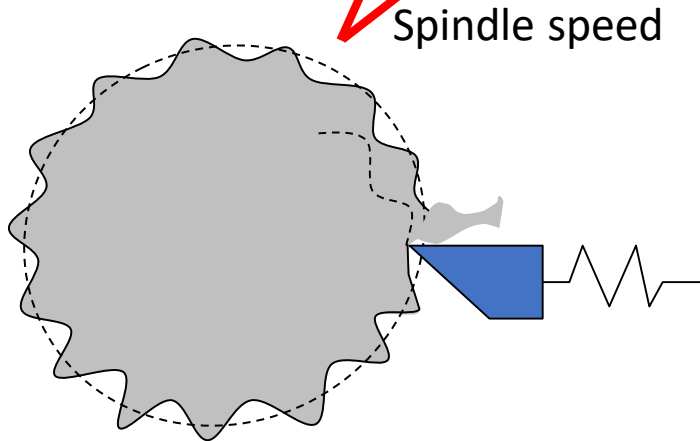
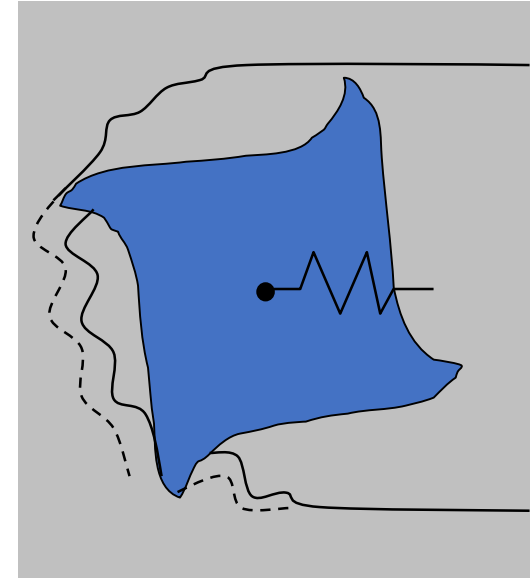

One more wave per revolution for left stable point

Machining background

How is a stability lobe diagram constructed?

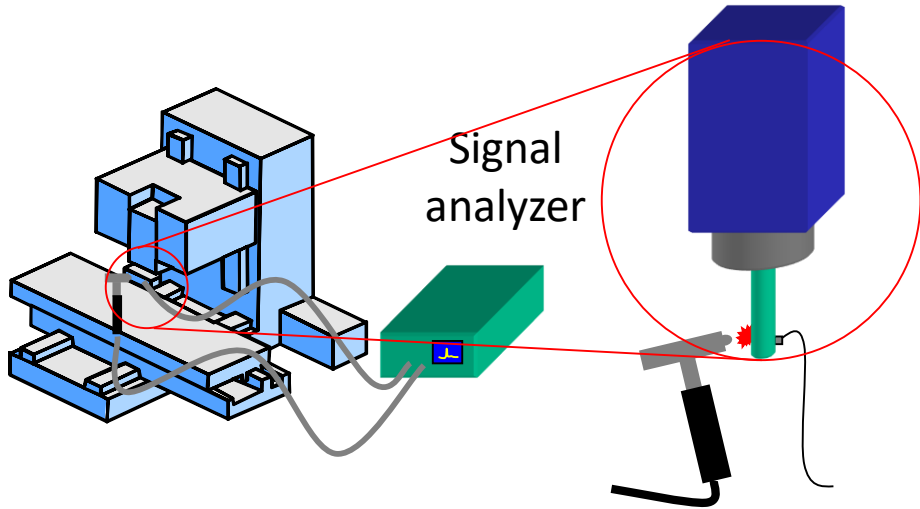

➔
Frequency Response
Function (FRF)

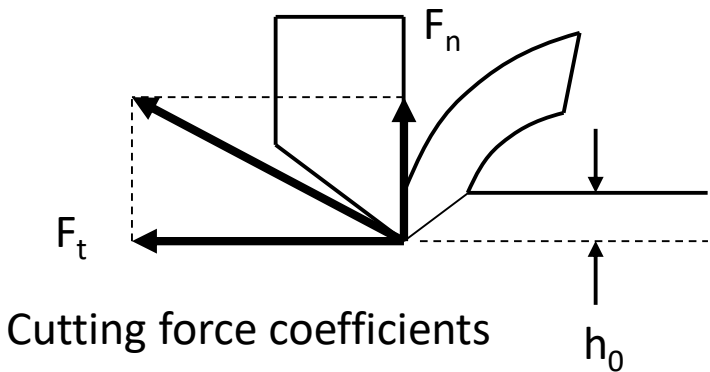
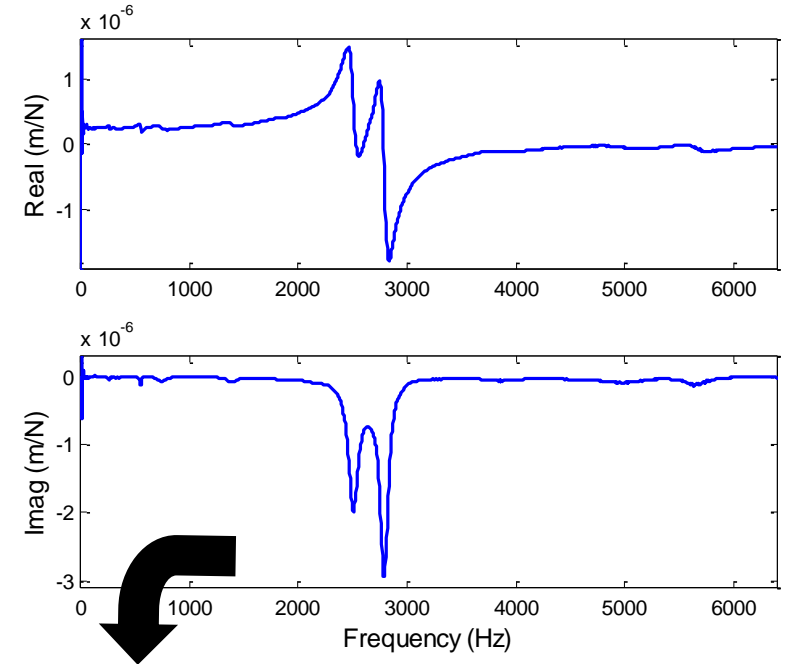

$$F_t = k_t h_0 b$$

$$F_n = k_n h_0 b$$

➔

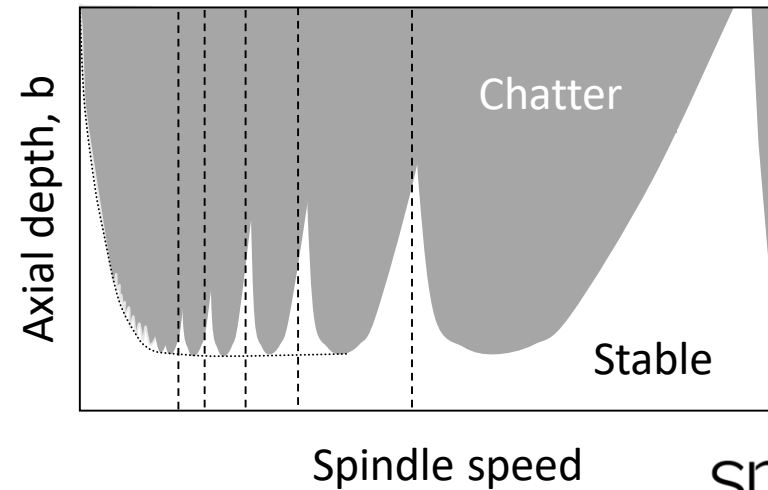

Outline

- Self-aware manufacturing
- Physics-guided machine learning
- Machining background
- **Stability modeling**
 - ANN
- Expanded stability modeling
- Summary

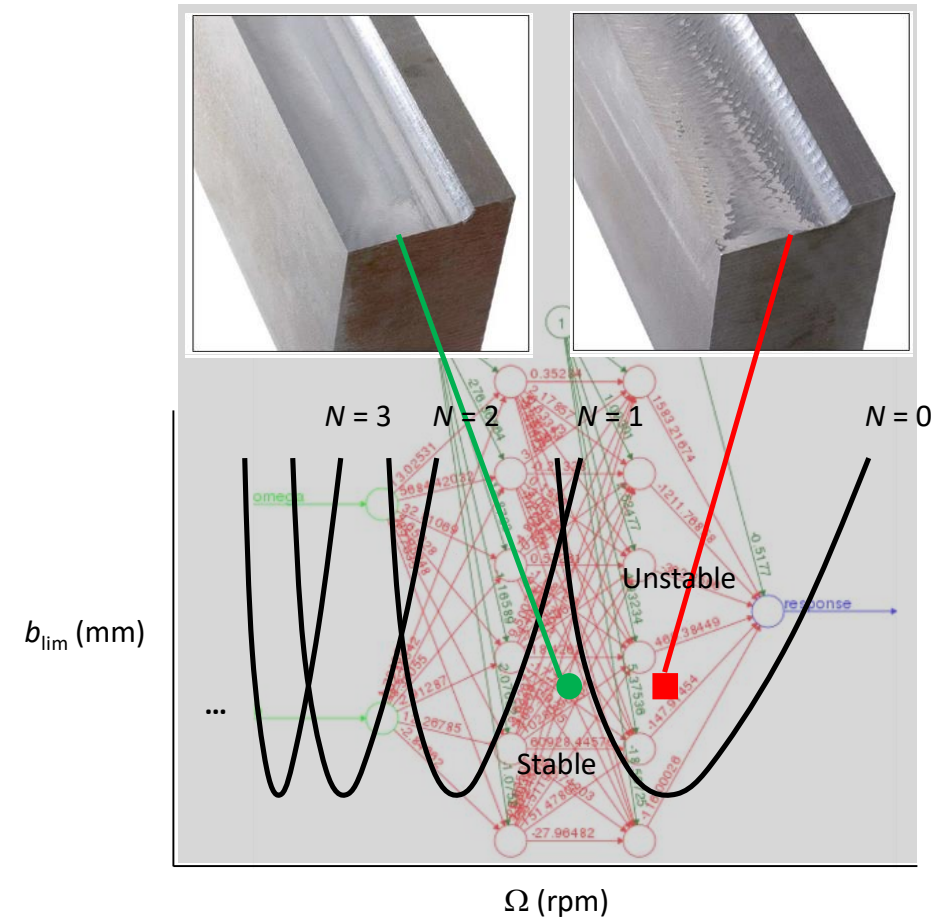

- Machining stability can be modeled analytically and numerically
- Physics-based model inputs include
 - structural dynamics (frequency response function)
 - force model (mechanistic coefficients)
 - tool/cut geometry (number of teeth, diameter, radial depth of cut)
- IIoT enables new data to be generated at high volume/rate with low cost
- Treat every cut as an experiment

- Challenge: physics-based models inputs have uncertainty, so optimized machining parameter predictions are also uncertain

- Objective: combine physics-based models with experiments using machine learning model, use data to update model

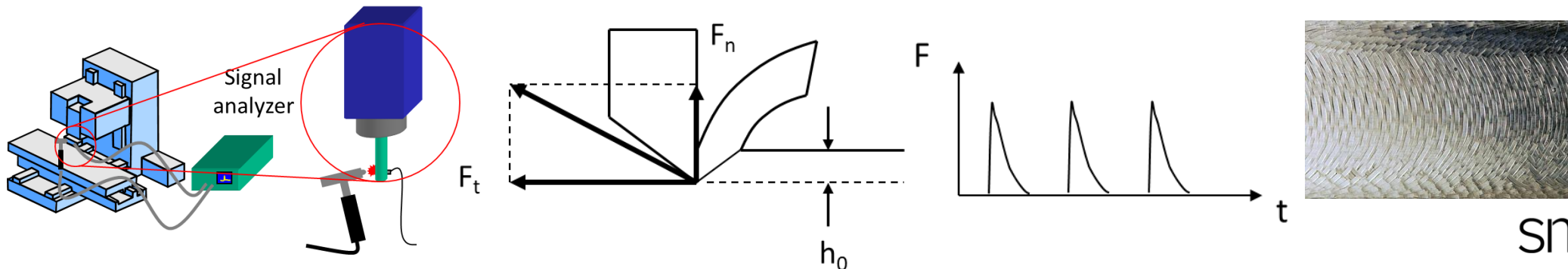

Stability modeling

- Data-learning models generally require a large amount of high quality data to train the model
- Approach here is to use the analytical turning stability limit to generate training data

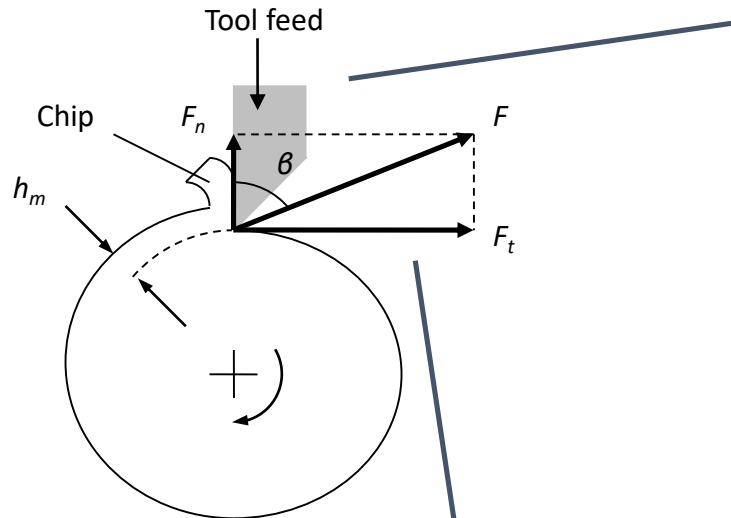
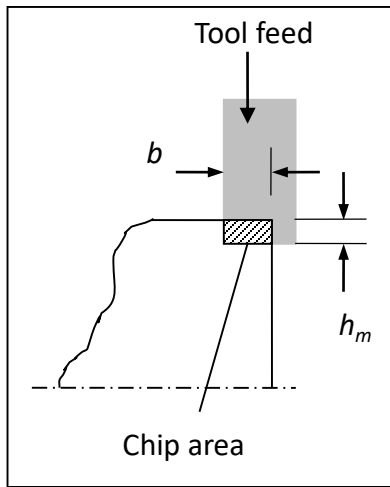

$$F = K_s A = K_s b h_m$$

$$F_n = \cos(\beta) F = \cos(\beta) K_s b h_m = k_n b h_m$$

$$F_t = \sin(\beta) F = \sin(\beta) K_s b h_m = k_t b h_m$$

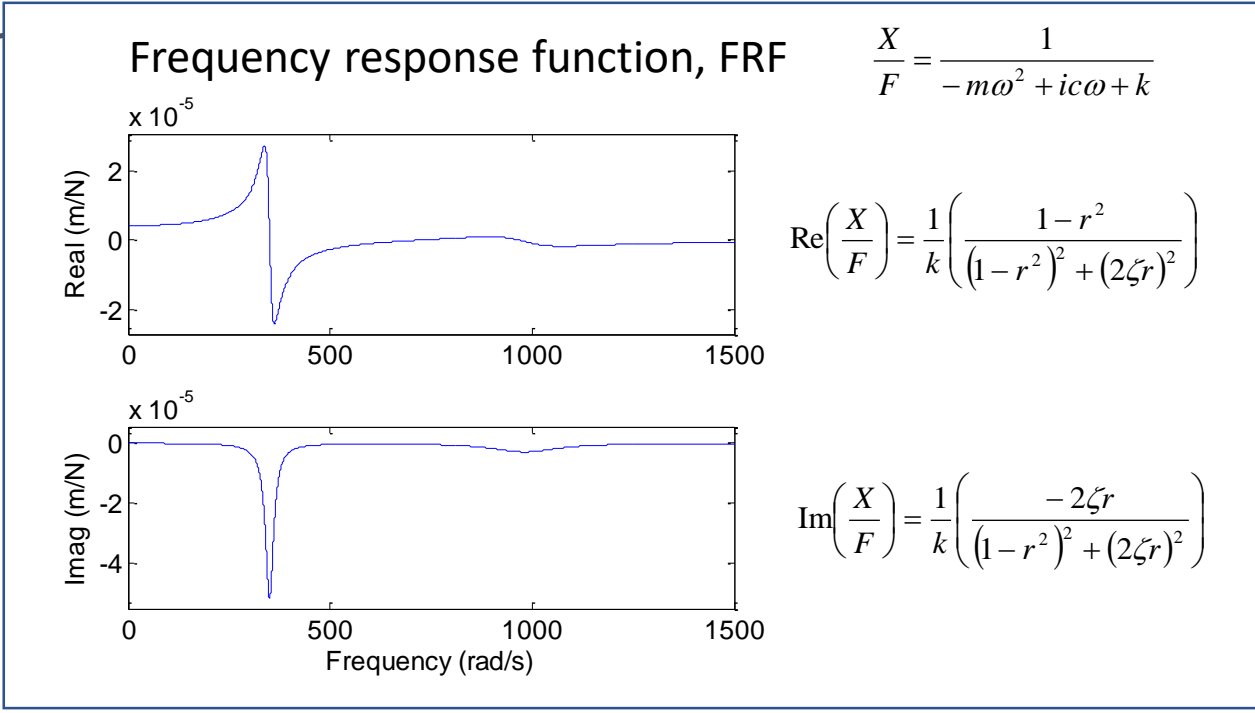

Stability modeling

- Machine learning models generally require a large amount of high quality data to train the model
- Approach here is to use the analytical turning stability limit to generate training data

Surface regeneration can lead to chatter, a self-excited vibration

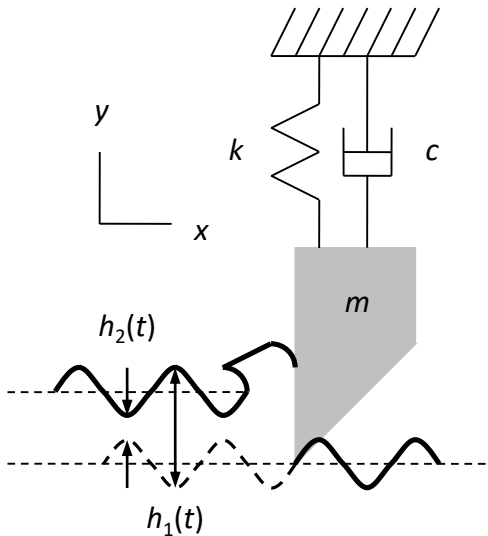

$$b_{lim} = \frac{-1}{2K_s \cos(\beta) \text{Re}[FRF]}$$

$$\frac{f_c}{\Omega} = N + \frac{\varepsilon}{2\pi}$$

$$\varepsilon = 2\pi - 2 \tan^{-1} \left(\frac{\text{Re}[FRF]}{\text{Im}[FRF]} \right)$$

Generate stability lobe diagram to relate spindle speed to limiting chip width

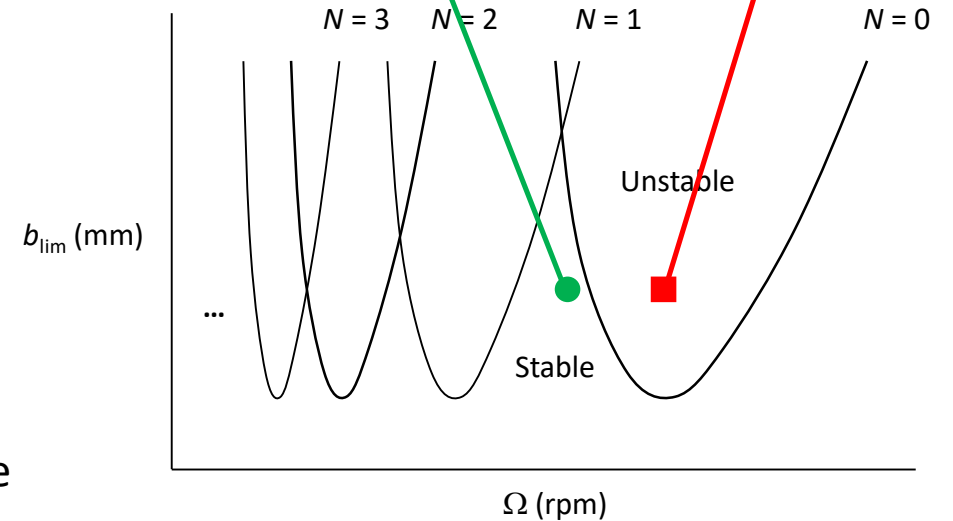
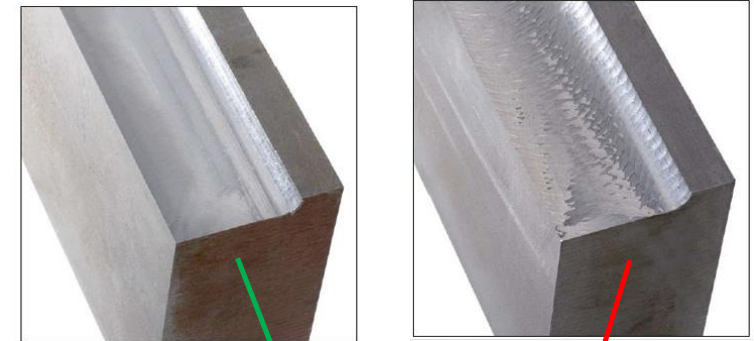

Stability modeling

The limiting chip width b_{lim} is calculated over a range of spindle speeds for a selected system.

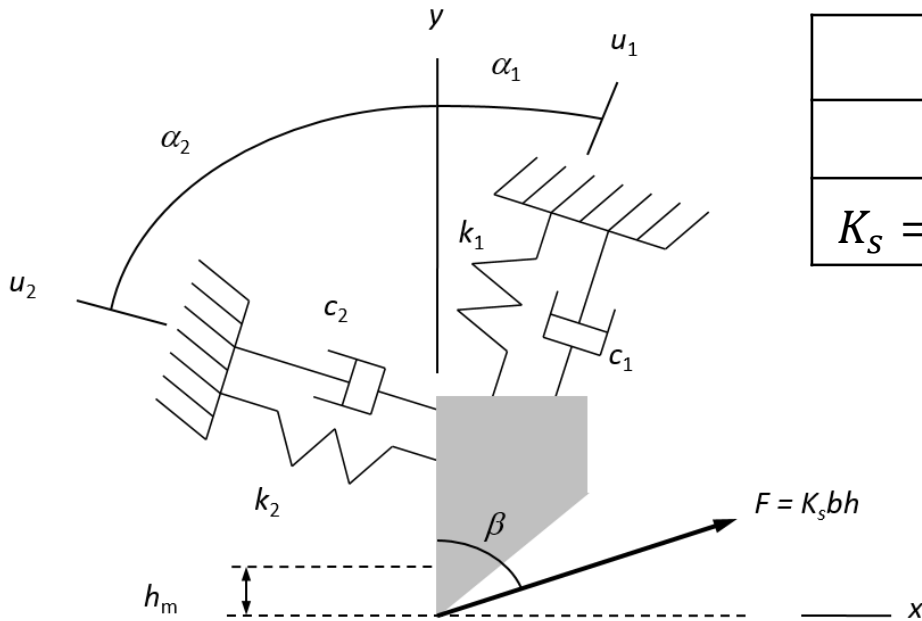

$\alpha_1 = 90^\circ$	$\beta = 70^\circ$	$k_1 = 1 \times 10^6 \text{ N/m}$	$k_1 = 1 \times 10^6 \text{ N/m}$
$\alpha_2 = 0^\circ$	$h_1 = 0.1 \text{ mm}$	$c_1 = 315 \text{ N-s/m}$	$c_2 = 315 \text{ N-s/m}$
$K_s = 700 \text{ N/mm}^2$		$m_1 = 2.5 \text{ kg}$	$m_2 = 2.5 \text{ kg}$

- The data for the proposed machine learning models consists of two sets: **training** and **test** datasets
- Both the sets are generated by randomly selecting the chip width values for N spindle speeds

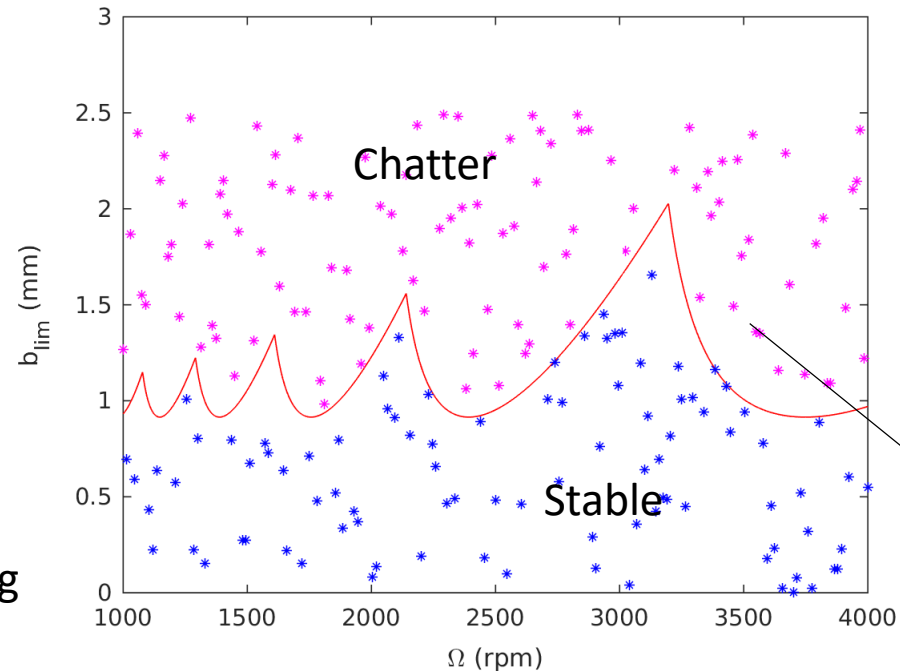

The graph of spindle speed vs. b_{lim} is the stability map.

Training data,
N = 201

- Stable/unstable machining is a classification problem
- Classification is a supervised learning approach in which the model learns from input data and then uses this learning to classify new observations
 - face image → male/female
 - spindle speed-chip width → stable/unstable
- Several approaches are available
 - Linear Classifiers: Logistic Regression, Naive Bayes Classifier
 - Support Vector Machines
 - Decision Trees
 - Boosted Trees
 - Random Forest
 - Artificial Neural Networks
 - Nearest Neighbor.

Outline

- Self-aware manufacturing
- Physics-guided machine learning
- Machining background
- Stability modeling
 - ANN
- Expanded stability modeling
- Summary

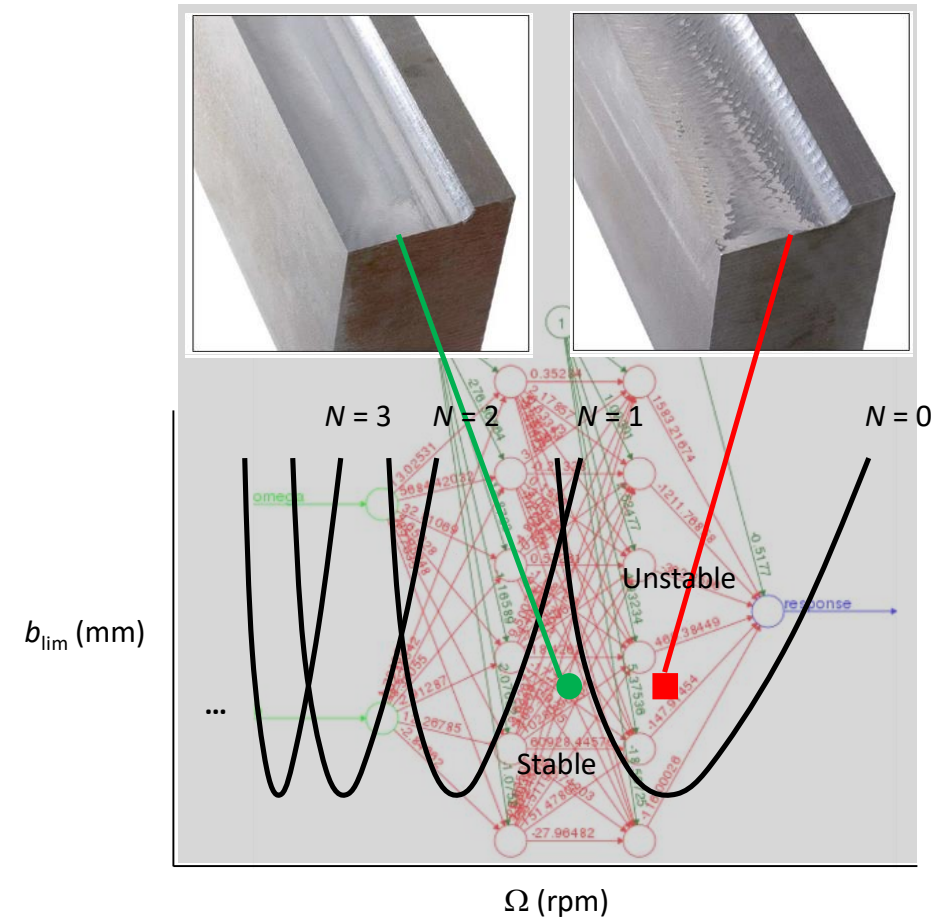

Stability modeling

- ANNs consist of **neurons** arranged in layers: an input layer, an output layer, and one or more hidden layers
- The neurons are connected to each other through **synapses**
- Each neuron takes inputs from the other layers, transforms them (using the **weights** associated with the synapses) to an output through an **activation function**
- The neurons in the output layer calculate the output variables using the input from the previous (hidden) layer

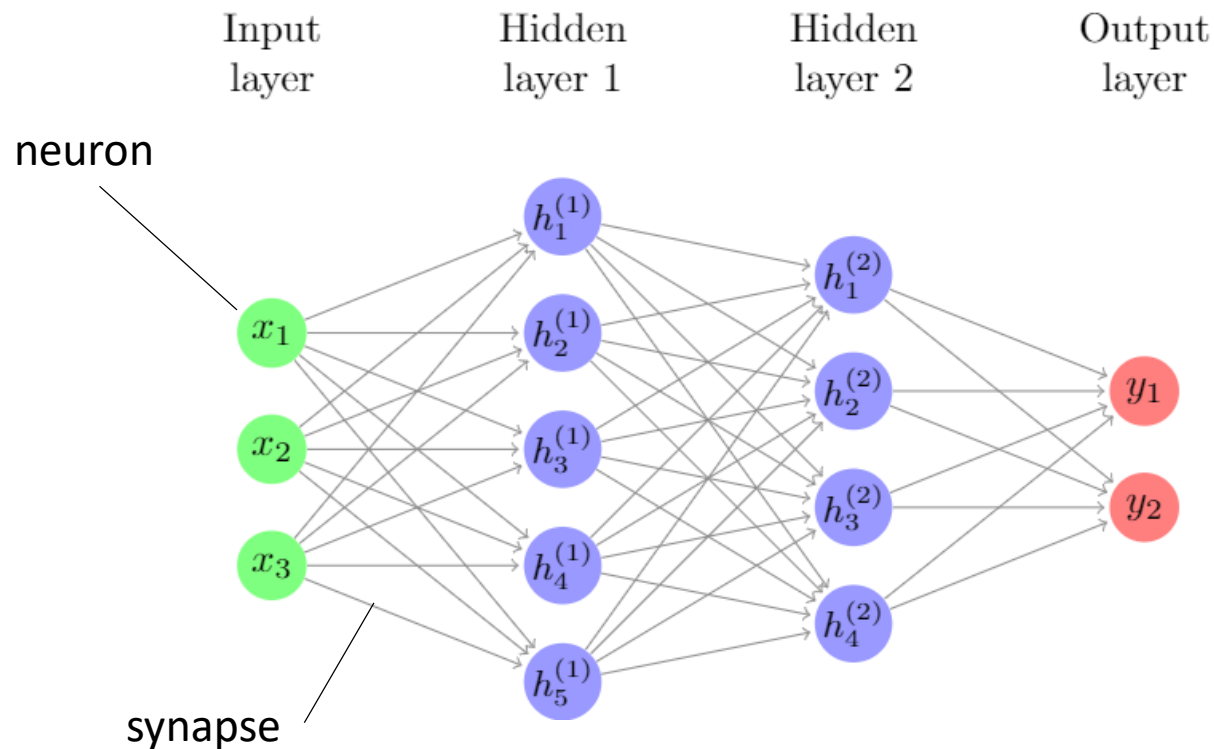

Artificial Neural Networks (ANNs) were applied to stability modeling.

Stability modeling

- Two input variables: chip width and spindle speed
- Output layer consists of only one node: a number between 0 and 1 (the likelihood of chatter occurring)
- Output ≥ 0.5 is taken to be chatter, Output < 0.5 is treated as stable
- Activation function: logistic function
- Error function: cross-entropy function

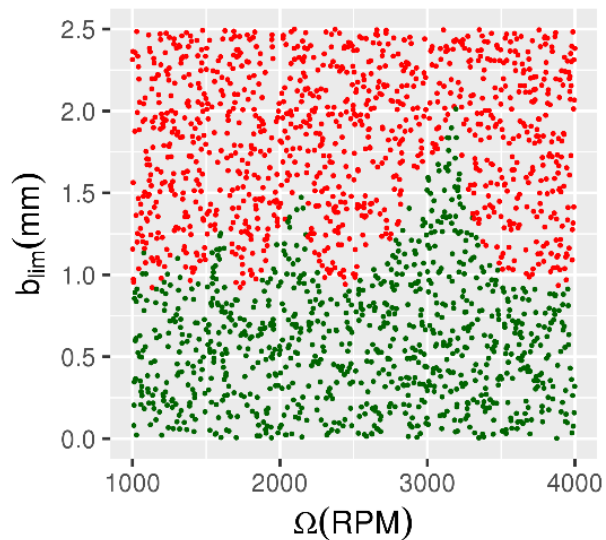

Response

- Stable
- Chatter

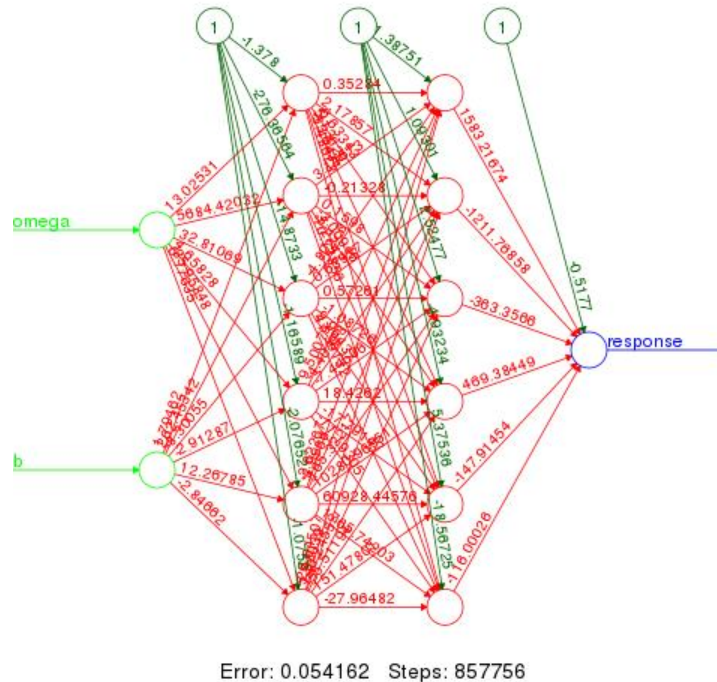

Two hidden layer, six neuron ANN

Predicted decision boundary

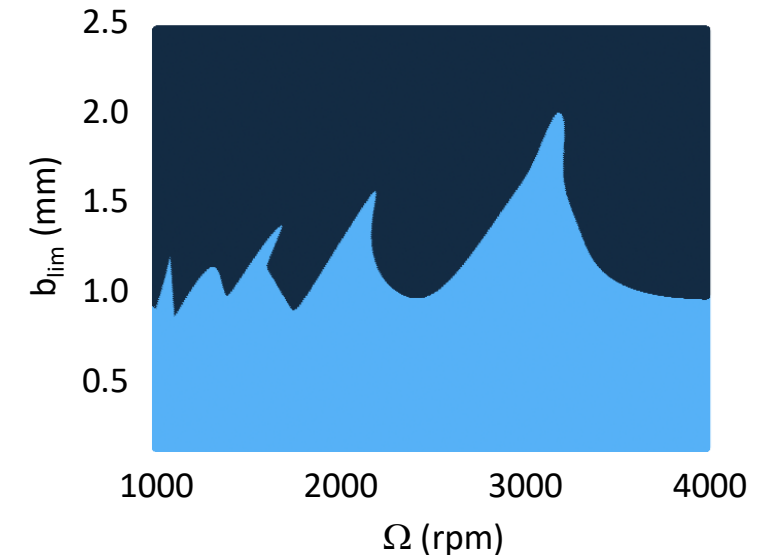

Training data: 2001 points

Model reproduced lobes using the training data. How well does it perform on the test data?

Stability modeling

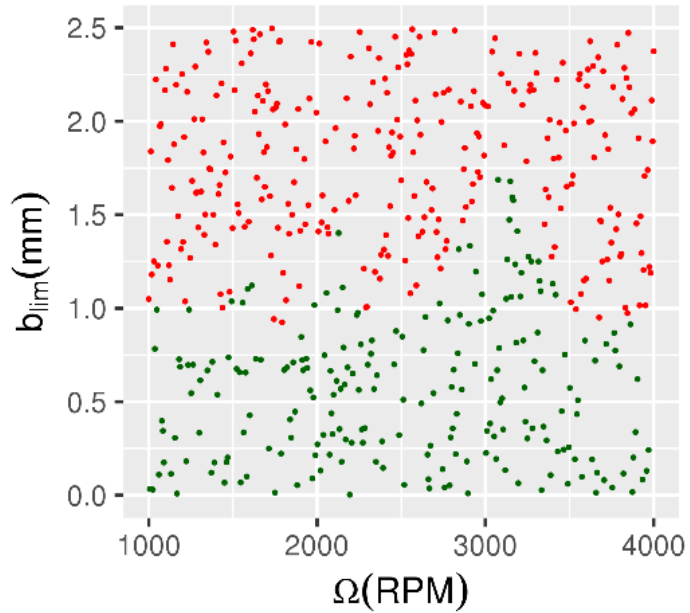

Response

- Stable
- Chatter

Test data: 501 points

		Predicted		
		Stable	Chatter	
Actual	Stable	215	2	217
	Chatter	1	283	284
		216	285	

Confusion matrix

The ANN model with two hidden layers is able to predict with 99.4% accuracy on the test data (498/501).

What if only one hidden layer with four neurons is used?

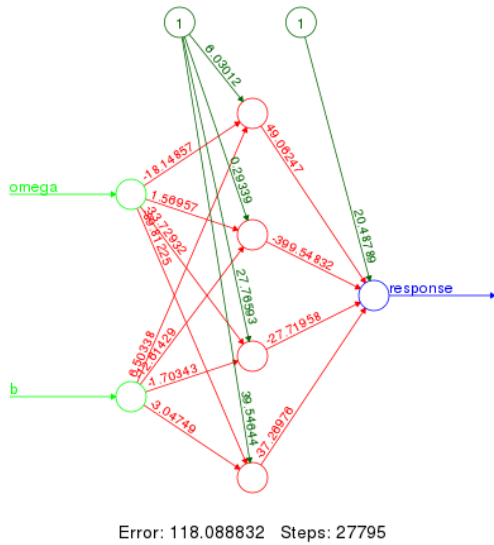

One hidden layer,
four neuron ANN

N = 201

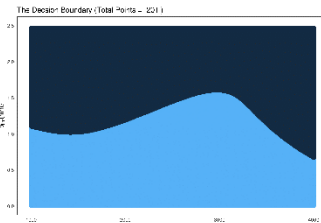

N = 601

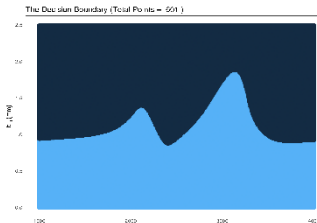

N = 2001

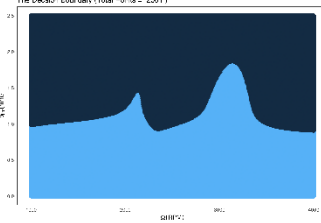

N = 2001

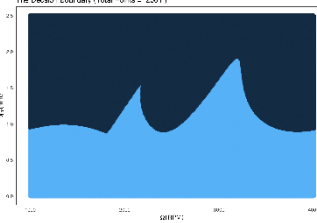

The stability lobe diagram is not predicted very well by the ANN model when only one hidden layer is used.

The bottom two cases correspond to the same number of points in the training data, but different distributions.

Training set

- data points generated using analytical stability model
- binary classification: stable or chatter

Experiments completed

- characterize behavior as stable or chatter
- data is in machine learning model domain (known spindle speed, depth of cut, and stability result)
- re-train model using new data

1. Use stability map to generate a data set (derived using uncertain FRF and force model)

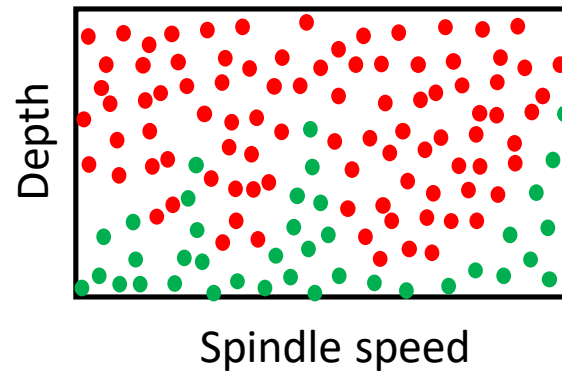
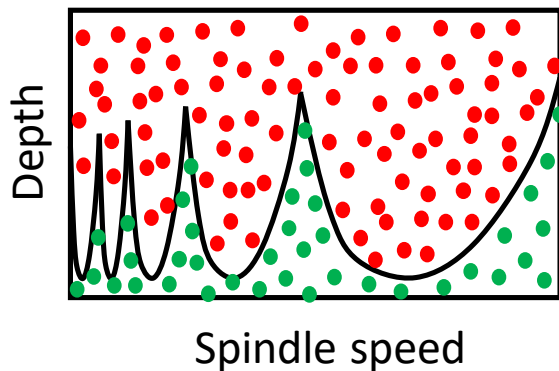

Training set

- data points generated using analytical stability model
- binary classification: stable or chatter

Experiments completed

- characterize behavior as stable or chatter
- data is in machine learning model domain (known spindle speed, depth of cut, and stability result)
- re-train model using new data

2. Use ANN to define stability model from data set (input uncertainty influences ANN)

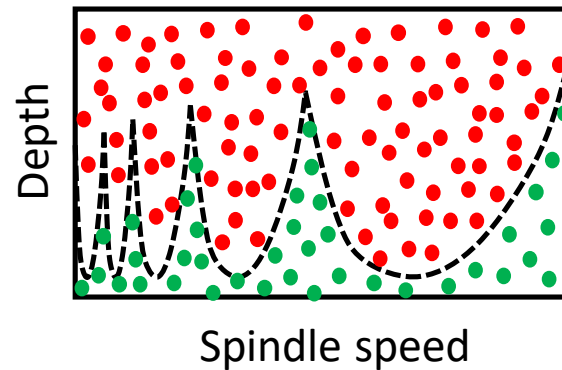
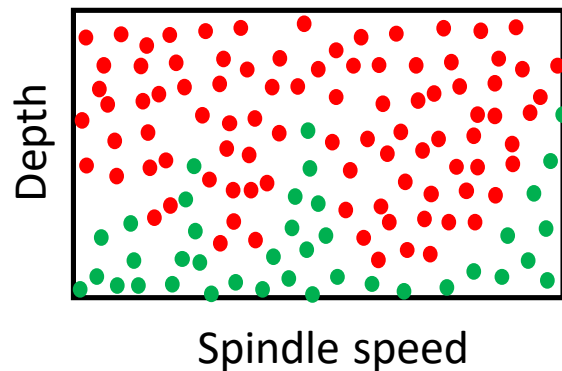

Training set

- data points generated using analytical stability model
- binary classification: stable or chatter

Experiments completed

- characterize behavior as stable or chatter
- data is in machine learning model domain (known spindle speed, depth of cut, and stability result)
- re-train model using new data

3. Collect data during experiments to determine stability for selected machining parameters

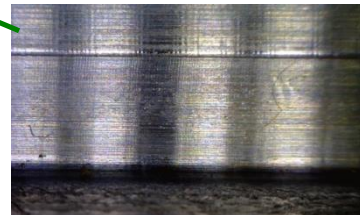
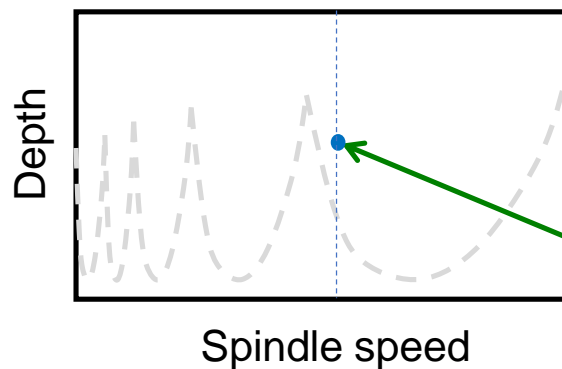

Example:

- cut is stable for initial model prediction of unstable
- at the selected spindle speed, the cut is therefore stable for all depths below the selected depth

Training set

- data points generated using analytical stability model
- binary classification: stable or chatter

Experiments completed

- characterize behavior as stable or chatter
- data is in machine learning model domain (known spindle speed, depth of cut, and stability result)
- re-train model using new data

4. Combine experimental data with ANN stability model to update model

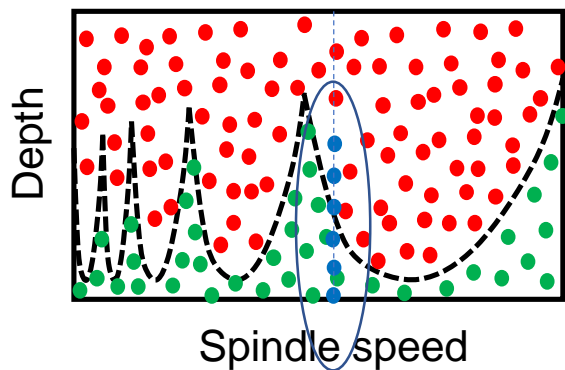

- stable experiment gives new knowledge about performance at selected spindle speed
- combine experimental points with data set
- use higher weight for experimental data
- update ANN stability model using all points
- reduce uncertainty and improve model accuracy over time

Outline

- Self-aware manufacturing
- Physics-guided machine learning
- Machining background
- Stability modeling
 - ANN
- **Expanded stability modeling**
- Summary

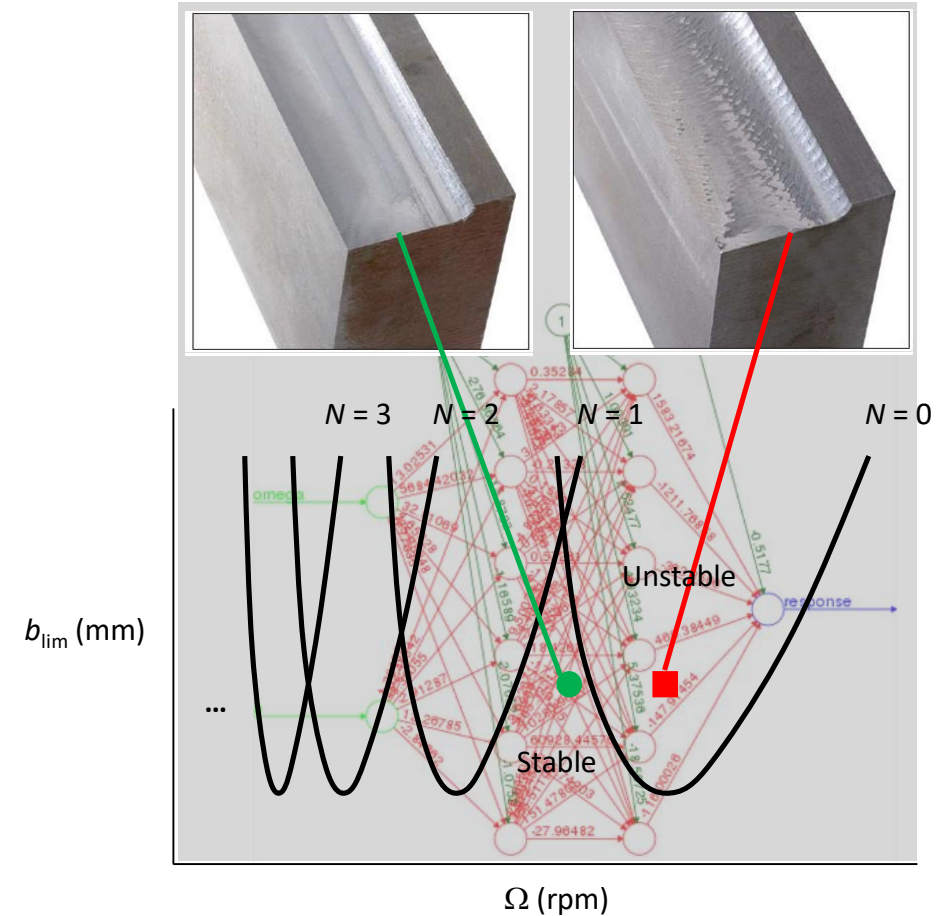

Expanded stability modeling

How is a stability lobe diagram constructed?

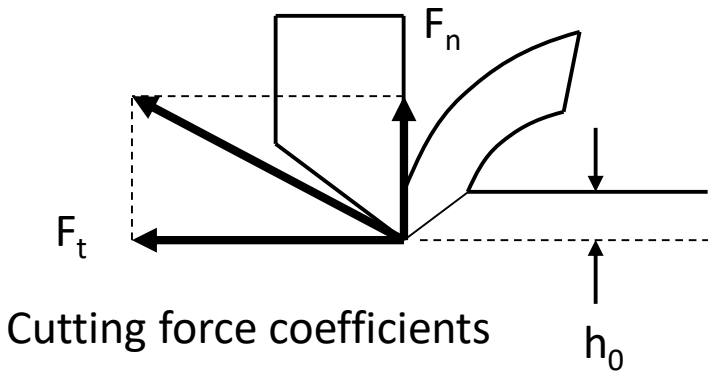
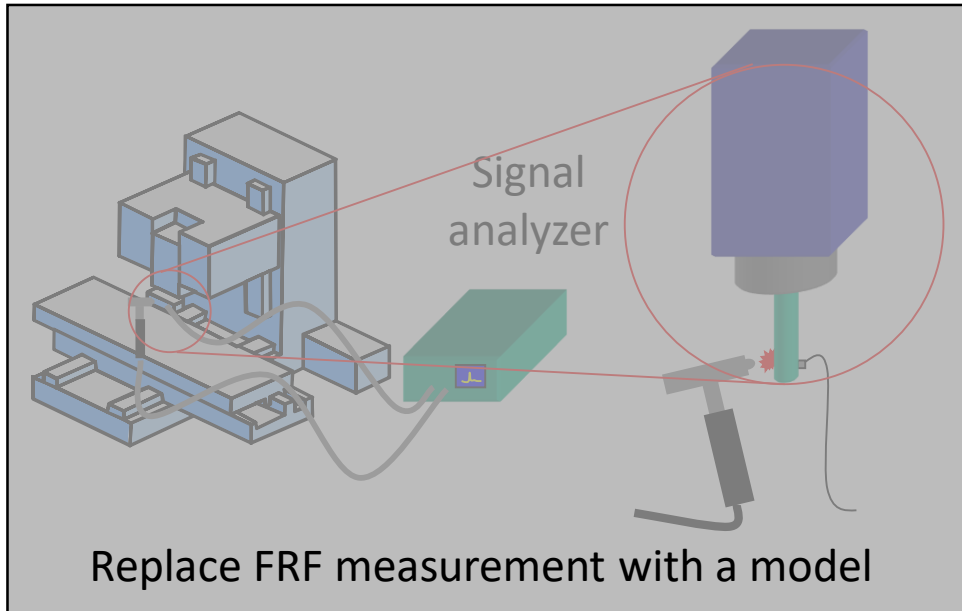

$$F_t = k_t h_0 b$$

$$F_n = k_n h_0 b$$

➔
Frequency Response
Function (FRF)

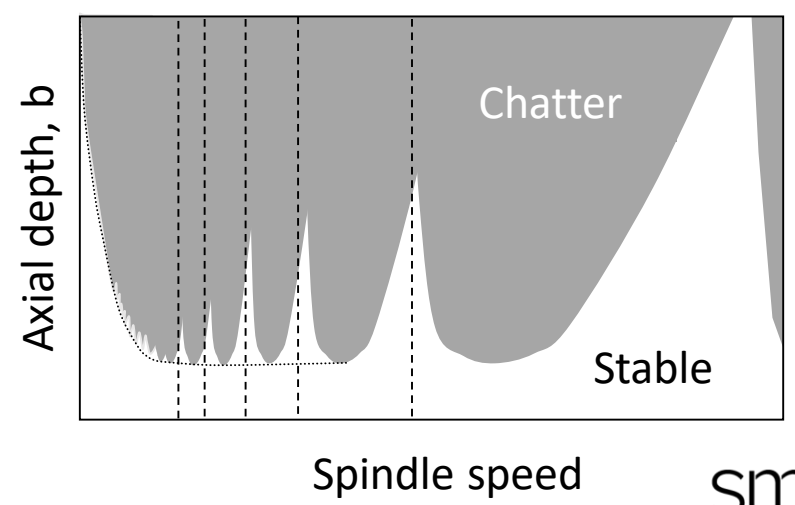
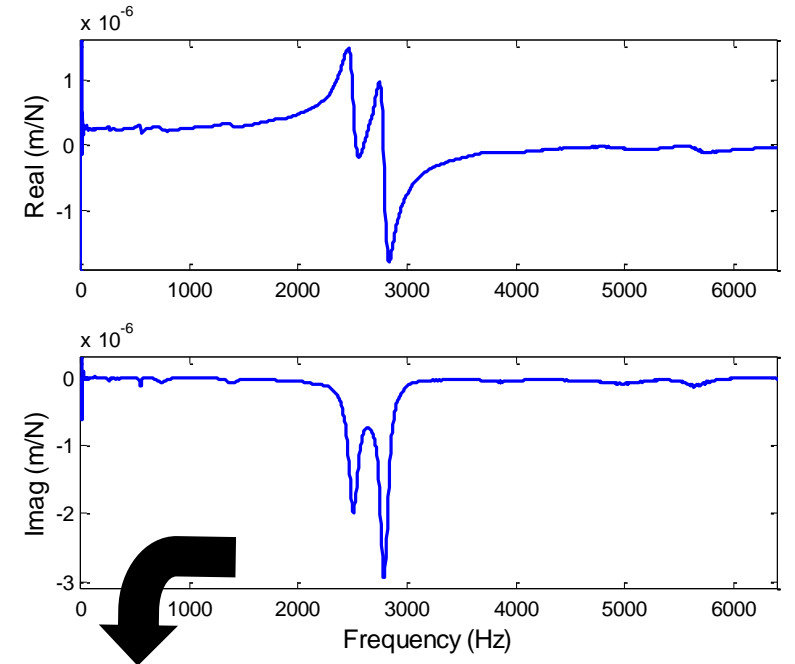

Expanded stability modeling

Predict tool point frequency response function, FRF, using receptance coupling substructure analysis, RCSA

- Determine spindle-machine FRF using standard holder

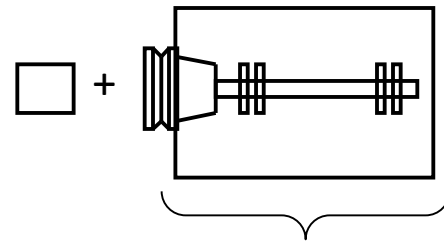
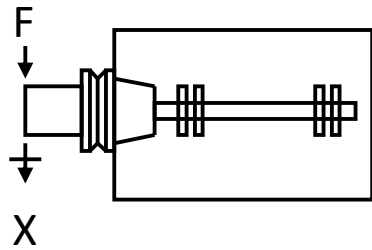

Archive spindle-machine FRF

- Model tool and holder

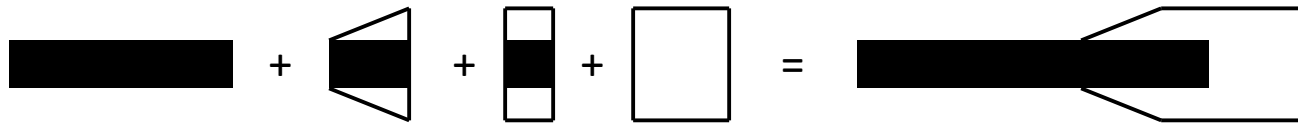

- Couple tool-holder model to spindle response and predict tool point FRF

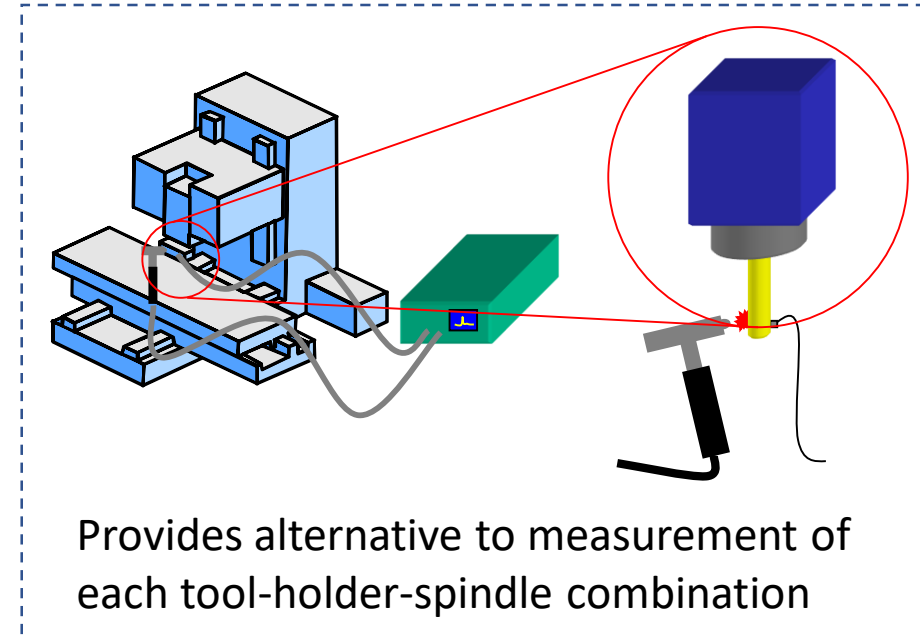
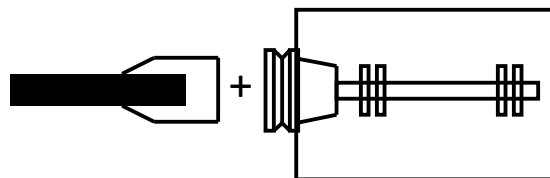

RCSA

- couple component FRFs to predict assembly FRFs
- consider both displacement and rotations, forces and moments

Cylinder component FRFs

$$\begin{matrix} h_{11} = \frac{x_1}{f_1} & l_{11} = \frac{x_1}{m_1} \\ n_{11} = \frac{\theta_1}{f_1} & p_{11} = \frac{\theta_1}{m_1} \end{matrix}$$

Generalized

$$\begin{Bmatrix} x_1 \\ \theta_1 \end{Bmatrix} = \begin{bmatrix} h_{11} & l_{11} \\ n_{11} & p_{11} \end{bmatrix} \begin{Bmatrix} f_1 \\ m_1 \end{Bmatrix} \quad \{u_1\} = [R_{11}]\{q_1\} \quad \text{Direct}$$

$$\begin{Bmatrix} x_1 \\ \theta_1 \end{Bmatrix} = \begin{bmatrix} h_{12a} & l_{12a} \\ n_{12a} & p_{12a} \end{bmatrix} \begin{Bmatrix} f_{2a} \\ m_{2a} \end{Bmatrix} \quad \{u_1\} = [R_{12a}]\{q_{2a}\} \quad \text{Cross}$$

$$\begin{Bmatrix} x_{2a} \\ \theta_{2a} \end{Bmatrix} = \begin{bmatrix} h_{2a1} & l_{2a1} \\ n_{2a1} & p_{2a1} \end{bmatrix} \begin{Bmatrix} f_1 \\ m_1 \end{Bmatrix} \quad \{u_{2a}\} = [R_{2a1}]\{q_1\} \quad \text{Cross}$$

$$\begin{Bmatrix} x_{2a} \\ \theta_{2a} \end{Bmatrix} = \begin{bmatrix} h_{2a1} & l_{2a1} \\ n_{2a1} & p_{2a1} \end{bmatrix} \begin{Bmatrix} f_1 \\ m_1 \end{Bmatrix} \quad \{u_{2a}\} = [R_{2a1}]\{q_1\} \quad \text{Direct}$$

Prismatic beam component FRFs

$$\begin{Bmatrix} x_{2b} \\ \theta_{2b} \end{Bmatrix} = \begin{bmatrix} h_{2b2b} & l_{2b2b} \\ n_{2b2b} & p_{2b2b} \end{bmatrix} \begin{Bmatrix} f_{2b} \\ m_{2b} \end{Bmatrix} \quad \{u_{2b}\} = [R_{2b2b}]\{q_{2b}\} \quad \text{Direct}$$

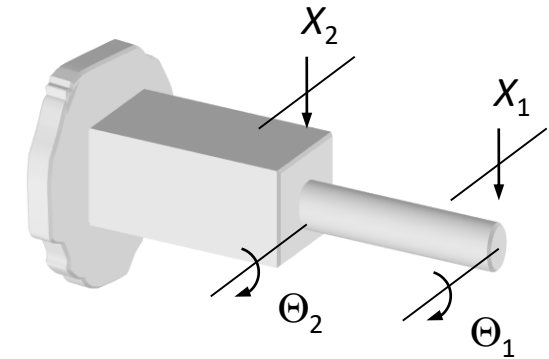

Assembly

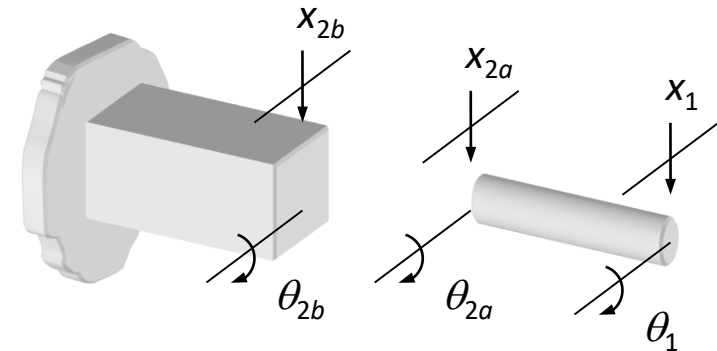

Components

Cylinder component generalized displacements

$$u_1 = R_{11}q_1 + R_{12a}q_{2a}$$

$$u_{2a} = R_{2a1}q_1 + R_{2a2a}q_{2a}$$

Prismatic beam component generalized displacement

$$u_{2b} = R_{2b2b}q_{2b}$$

Compatibility condition (rigid)

$$u_{2b} - u_{2a} = 0$$

Equilibrium conditions

$$q_{2a} + q_{2b} = 0 \quad q_1 = Q_1$$

Substituting

$$u_{2b} - u_{2a} = 0$$

$$R_{2b2b}q_{2b} - R_{2a1}q_1 - R_{2a2a}q_{2a} = 0$$

$$(R_{2a2a} + R_{2b2b})q_{2b} - R_{2a1}Q_1 = 0$$

$$q_{2b} = (R_{2a2a} + R_{2b2b})^{-1} R_{2a1}Q_1$$

$$G_{11} = \frac{U_1}{Q_1} = \frac{u_1}{Q_1} = \frac{R_{11}q_1 + R_{12a}q_{2a}}{Q_1} = \frac{R_{11}Q_1 - R_{12a}(R_{2a2a} + R_{2b2b})^{-1}R_{2a1}Q_1}{Q_1}$$

$$G_{11} = \underbrace{R_{11} - R_{12a}(R_{2a2a} + R_{2b2b})^{-1}R_{2a1}}_{\text{Components}} = \begin{bmatrix} H_{11} & L_{11} \\ N_{11} & P_{11} \end{bmatrix}$$

Assembly
Components

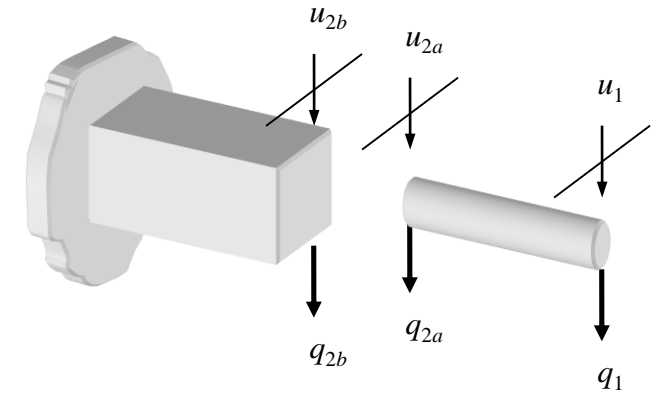

Components

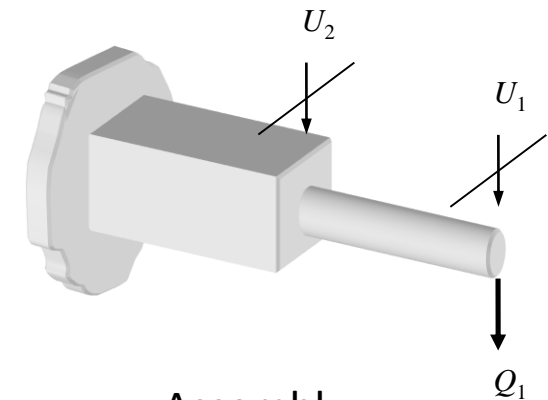

Assembly

Expanded stability modeling

Expanded modeling steps

1. Predict tool point FRF using receptance coupling substructure analysis (RCSA)
2. Generate stability map using predicted FRF and archived force model
3. Use stability map to generate a data set
4. Define data learning stability model from data set
5. Collect data during experiments to determine actual stability for selected machining parameters
6. Combine experimental data with training data to update data learning stability model

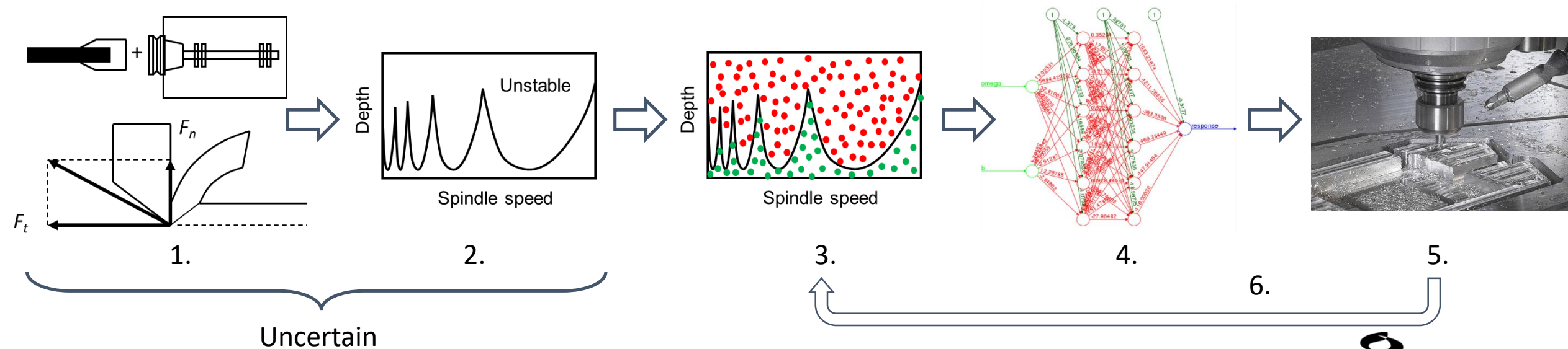

Expanded stability modeling

Hybrid physics-guided data learning

- combine data-driven and physics-based models with process measurements
- train model using points obtained from analytical stability map
- update model with experimental results
- Improve model accuracy

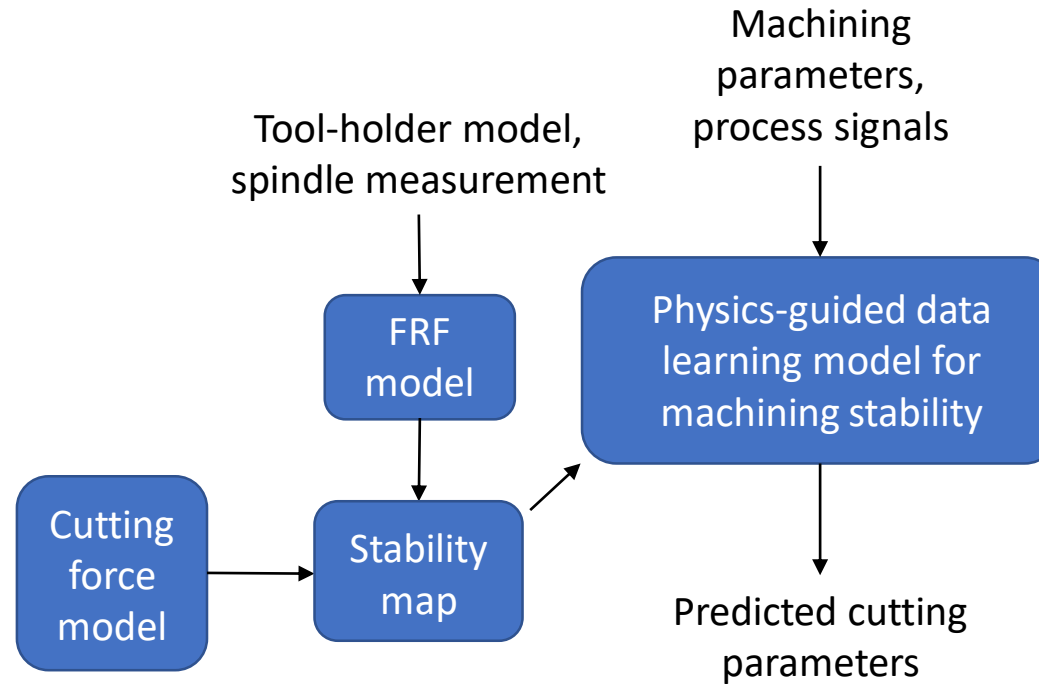

Summary

- Self-aware manufacturing
- Physics-guided machine learning
- Machining background
- Stability modeling
 - ANN
- Expanded stability modeling
- Summary

Questions?

Tony Schmitz
University of Tennessee, Knoxville/ORNL
tony.schmitz@utk.edu

